

Product Summary

The GESDK5V0LE4 is designed to protect voltage sensitive electronic components from ESD and other transients. Excellent clamping capability, low leakage, low capacitance, and fast response time provide best in class protection on designs that are exposed to ESD.

The combination of small size, low capacitance, and high level of ESD protection makes them a flexible solution for applications such as HDMI, Display Port TM, and MDDI interfaces. It is designed to replace multiplayer varistors (MLV) in consumer equipment applications such as mobile phone, notebook, PAD, STB, LCD TV etc.

Feature

- Low reverse stand-off voltage: 5V Max.
- Bi-directional ESD protection of one line
- Low capacitance: 10pF(Typ.)
- Low reverse clamping voltage
- Low leakage current
- Excellent package:1.6mm×1.2mm×0.6mm
- Fast response time
- IEC 61000-4-2 Level 3 ESD protection
- JESD22-A114-B ESD Rating of class 3B per human

Application

- Digital cameras
- Computers and peripherals
- PAD
- Cellular handsets and accessories
- Portable electronics
- LCD TV
- Other electronics equipment communication systems

SOT-553

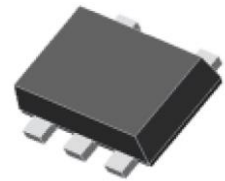

Schematic diagram

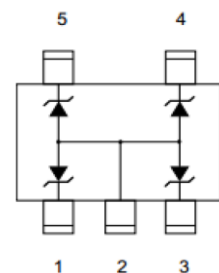

Absolute Maximum Ratings ($T_a=25^{\circ}\text{C}$ unless otherwise noted)

Parameter	Symbol	Value	Unit
IEC 61000-4-2 ESD Voltage	$V_{\text{ESD}}^{1)}$	± 10	KV
IEC 61000-4-2 ESD Voltage		± 10	
JESD22-A114-B ESD Voltage		± 15	
ESD Voltage		± 0.4	
Peak Pulse Power	$P_{\text{PP}}^{2)}$	30	W
Peak Pulse Current	$I_{\text{PP}}^{2)}$	2	A
Lead Solder Temperature – Maximum (10 Second Duration)	T_L	260	$^{\circ}\text{C}$
Junction Temperature	T_j	125	$^{\circ}\text{C}$
Storage Temperature Range	T_{stg}	-45~ +125	$^{\circ}\text{C}$

- 1) Device stressed with ten non-repetitive ESD pulses.
- 2) Non-repetitive current pulse $8/20\mu\text{s}$ exponential decay waveform according to IEC61000-4-5.

ESD standards compliance

IEC61000-4-2 Standard

Contact Discharge		Air Discharge	
Level	Test Voltage kV	Level	Test Voltage kV
1	2	1	2
2	4	2	4
3	6	3	8
4	8	4	15

JESD22-A114-B Standard

ESD Class	Human Body Discharge V
0	0~249
1A	250~499
1B	500~999
1C	1000~1999
2	2000~3999
3A	4000~7999
3B	8000~15999

Contact discharge current waveform per IEC61000-4-2

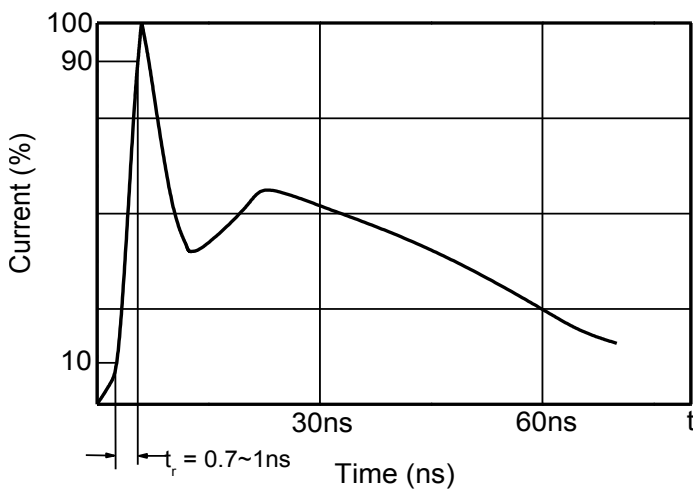

8/20 μs waveform per IEC61000-4-5

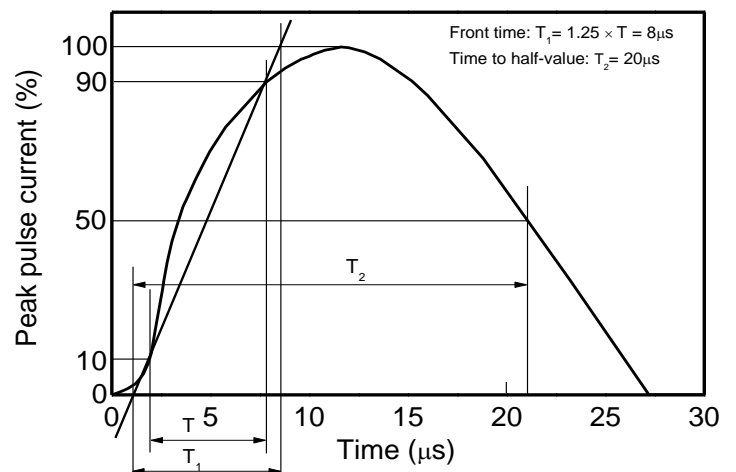

Electrical Parameter

Symbol	Parameter
V _C	Clamping Voltage @ I _{PP}
I _{PP}	Peak Pulse Current
V _{BR}	Breakdown Voltage @ I _T
I _T	Test Current
I _R	Reverse Leakage Current @ V _{RWM}
V _{RWM}	Reverse Standoff Voltage

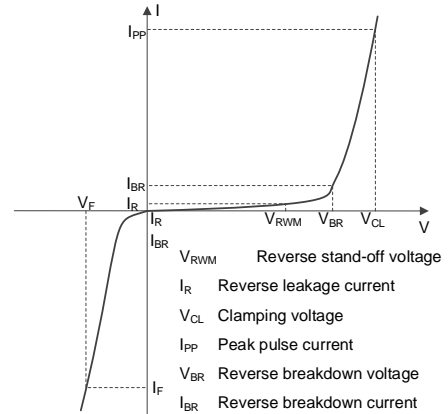

V-I characteristics for a Uni-directional TVS

Electrical Characteristics (Ta=25°C unless otherwise specified)

Parameter	Symbol	Test conditions	Min.	Typ.	Max.	Unit
Reverse stand-off voltage	V _{RWM} ¹⁾				5	V
Reverse leakage current	I _R	V _{RWM} =5V			1	uA
Breakdown voltage	V _{BR}	I _T =1mA	6		7.5	V
Clamping voltage	V _C ²⁾	I _{PP} =2A			15	V
Junction capacitance	C _J	V _R =0V, f=1MHz		10	15	pF

1) Pin 1,3,4,5 to Pin 2.

2) Non-repetitive current pulse 8/20μs exponential decay waveform according to IEC61000-4-5

SOT-553 Package Outline Dimensions

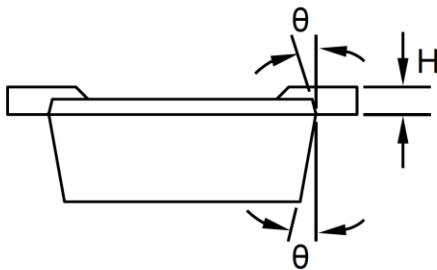
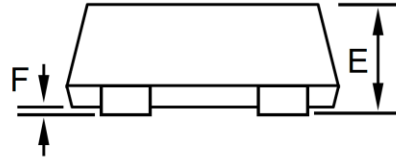
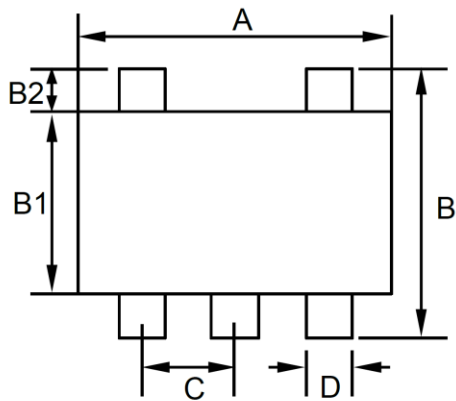

SOT-553 (unit: mm)		
Dim.	Min.	Max.
A	1.50	1.70
B	1.50	1.70
B1	1.10	1.30
B2	0.10	0.30
C	0.45	0.55
D	0.17	0.27
E	0.50	0.60
F	0.00	0.05
H	0.08	0.16
θ	7° REF.	

Recommend PCB Layout (unit: mm)

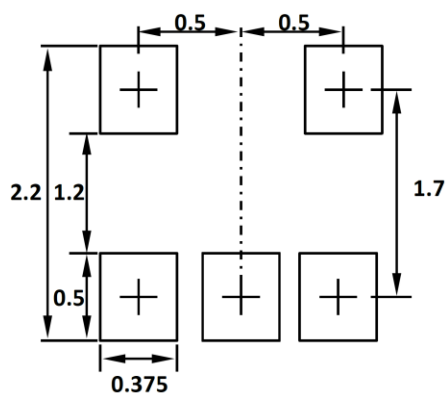

Notes:

This recommended layout is for reference purposes only.

If there is enough place in PCB. It can be mounted with copper along the dotted line in order to optimize thermal design.