



Product Summary

$V_{(BR)DSS}$	$R_{DS(on)TYP}$	I_D
40V	6.3m Ω @10V	80A
	7.9m Ω @4.5V	

Feature

- Trench Technology Power MOSFET
- Low $R_{DS(ON)}$
- Low Gate Charge
- Low Gate Resistance
- 100% UIS Tested

Application

- Power Switching Application

MARKING:



M082N04N = Device Code
XX = Date Code
Solid Dot = Green Indicator

TO-220-3L-C

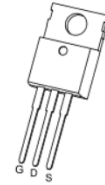

Schematic diagram

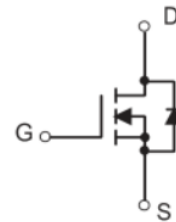

ABSOLUTE MAXIMUM RATINGS ($T_A = 25^\circ\text{C}$ unless otherwise noted)

Parameter	Symbol	Value	Unit
Drain - Source Voltage	V_{DS}	40	V
Gate - Source Voltage	V_{GS}	± 20	V
Continuous Drain Current ¹	I_D	80	A
Continuous Drain Current ⁶			
Pulsed Drain Current ²	I_{DM}	180	A
Single Pulsed Avalanche Current ³	I_{AS}	40	A
Single Pulsed Avalanche Energy ³	E_{AS}	80	mJ
Power Dissipation ⁵	P_D	41.6	W
Power Dissipation ⁶			
Thermal Resistance from Junction to Ambient ⁶	$R_{\theta JA}$	55	$^\circ\text{C/W}$
Thermal Resistance from Junction to Case	$R_{\theta JC}$	3	$^\circ\text{C/W}$
Junction Temperature	T_J	-55~ +150	$^\circ\text{C}$
Storage Temperature	T_{STG}	-55~ +150	$^\circ\text{C}$

MOSFET ELECTRICAL CHARACTERISTICS ($T_J = 25^\circ\text{C}$ unless otherwise noted)

Parameter	Symbol	Test Condition	Min	Type	Max	Unit
Off Characteristics						
Drain - Source Breakdown Voltage	$V_{(BR)DSS}$	$V_{GS} = 0V, I_D = 250\mu A$	40			V
Zero Gate Voltage Drain Current	I_{DSS}	$V_{DS} = 32V, V_{GS} = 0V$			1	μA
Gate - Body Leakage Current	I_{GSS}	$V_{GS} = \pm 20V, V_{DS} = 0V$			± 100	nA
On Characteristics⁴						
Gate Threshold Voltage	$V_{GS(th)}$	$V_{DS} = V_{GS}, I_D = 250\mu A$	1.0	1.6	3.0	V
Drain-source On-resistance	$R_{DS(on)}$	$V_{GS} = 10V, I_D = 10A$		6.3	8.2	m Ω
		$V_{GS} = 4.5V, I_D = 10A$		7.9	11.8	
Forward Transconductance	g_{FS}	$V_{DS} = 10V, I_D = 10A$		12		S
Dynamic Characteristics						
Input Capacitance	C_{iss}	$V_{DS} = 20V, V_{GS} = 0V, f = 1MHz$		3163		pF
Output Capacitance	C_{oss}			240		
Reverse Transfer Capacitance	C_{rss}			214		
Gate Resistance	R_g	$V_{DS} = 0V, V_{GS} = 0V, f = 1MHz$		1.59		Ω
Switching Characteristics						
Total Gate Charge	Q_g	$V_{DS} = 25V, V_{GS} = 10V, I_D = 8A$		20		nC
Gate-source Charge	Q_{gs}			9		
Gate-drain Charge	Q_{gd}			11		
Turn-on Delay Time	$t_{d(on)}$	$V_{DD} = 15V, V_{GS} = 10V, R_L = 3\Omega, R_G = 3\Omega$		15		ns
Turn-on Rise Time	t_r			5		
Turn-off Delay Time	$t_{d(off)}$			50		
Turn-off Fall Time	t_f			6		
Source - Drain Diode Characteristics						
Diode Forward Voltage ⁴	V_{SD}	$V_{GS} = 0V, I_S = 10A$			1.2	V

Notes :

- 1.The maximum current rating is limited by package.And device mounted on a large heatsink
- 2.Pulse Test : Pulse Width $\leq 10\mu s$, duty cycle $\leq 1\%$.
- 3.EAS condition: $V_{DD} = 25V, V_{GS} = 10V, L = 0.1mH, R_G = 25\Omega$ Starting $T_J = 25^\circ\text{C}$.
- 4.Pulse Test : Pulse Width $\leq 300\mu s$, duty cycle $\leq 2\%$.
- 5.The power dissipation P_D is limited by $T_{J(MAX)} = 150^\circ\text{C}$.And device mounted on a large heatsink
- 6.Device mounted on $1in^2$ FR-4 board with 2oz. Copper, in a still air environment with $T_A = 25^\circ\text{C}$.

Typical Characteristics

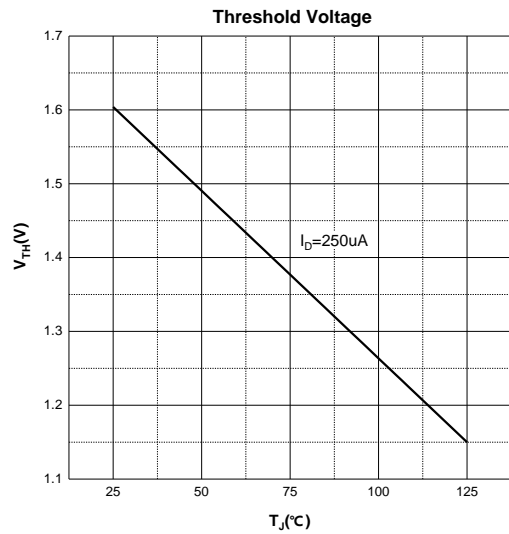
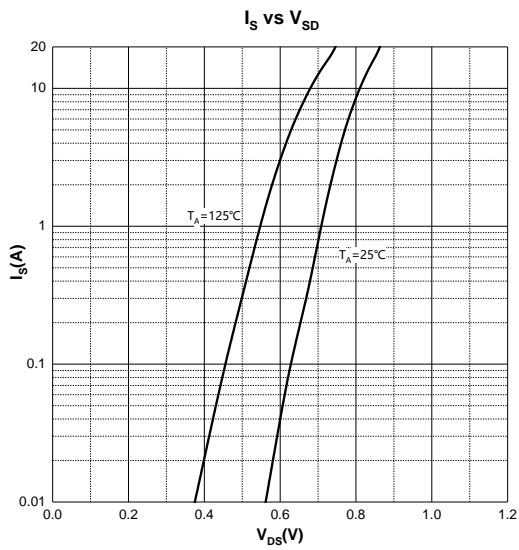
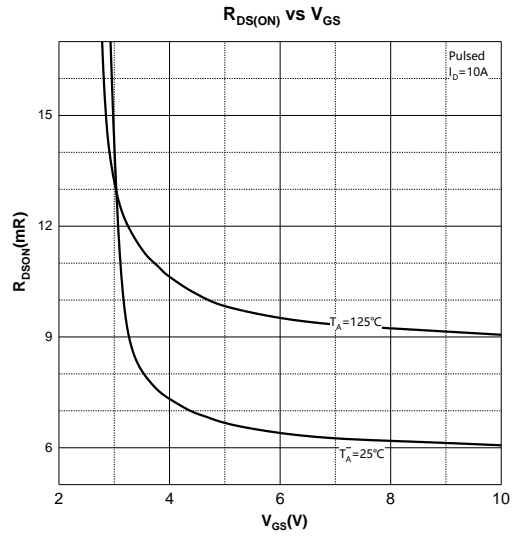
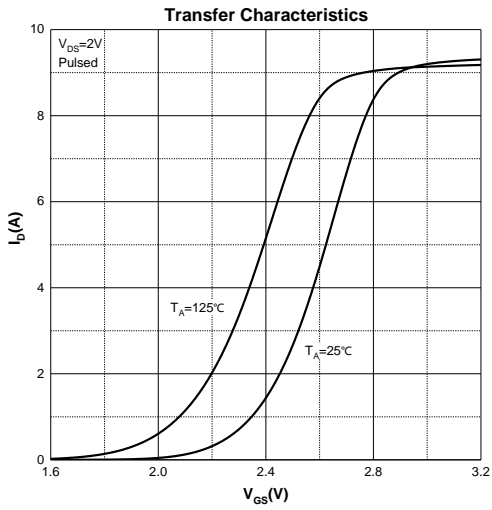
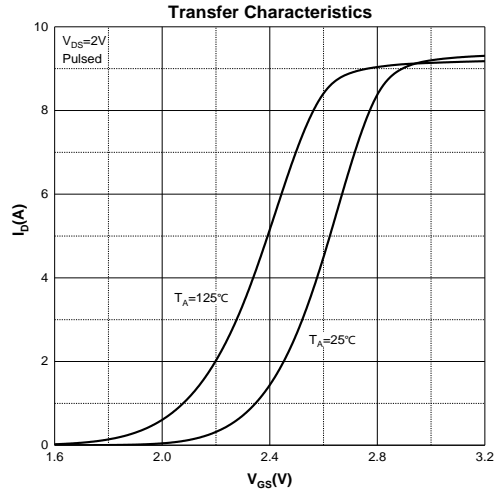
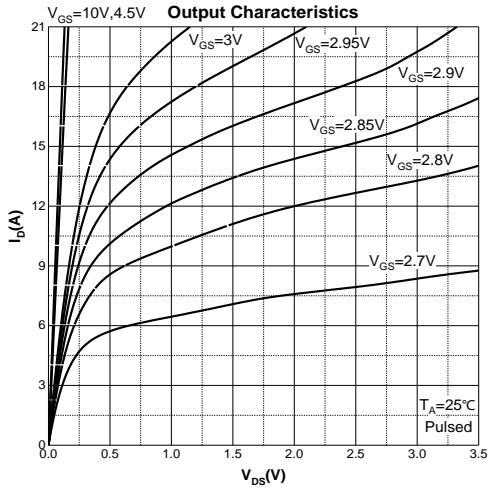

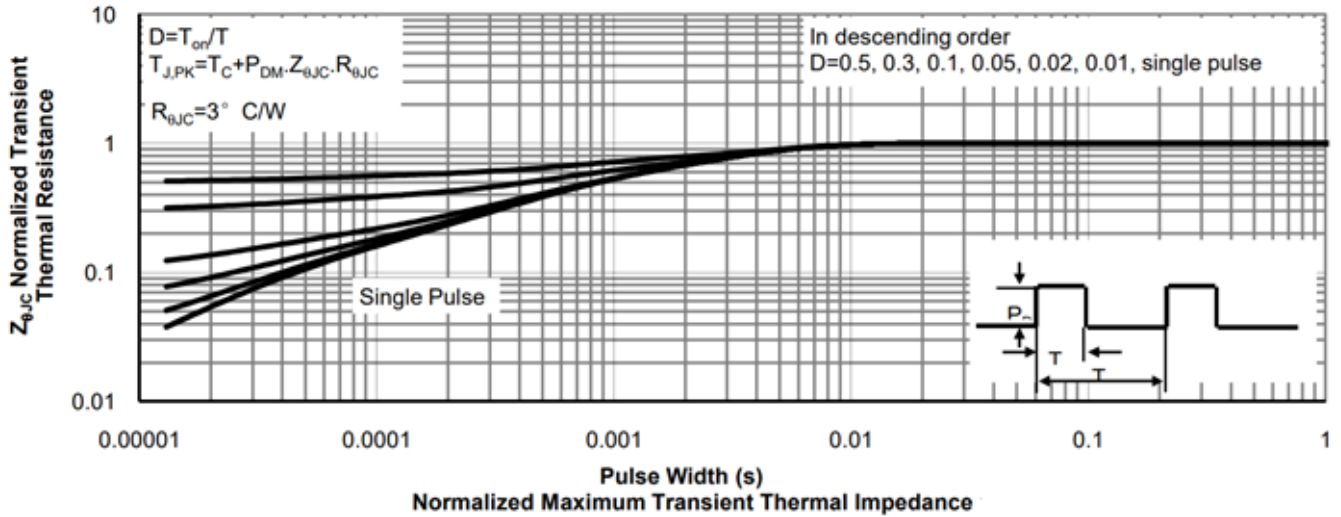
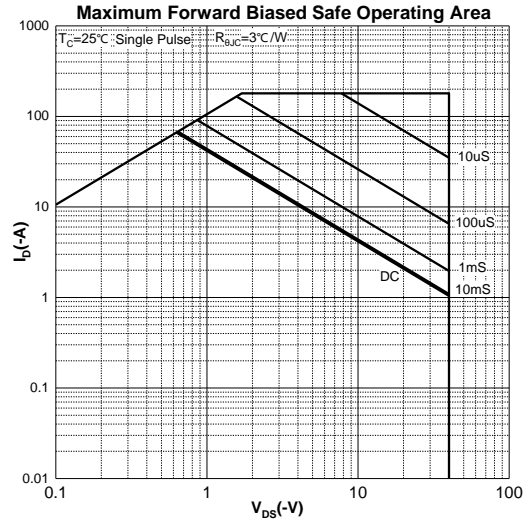
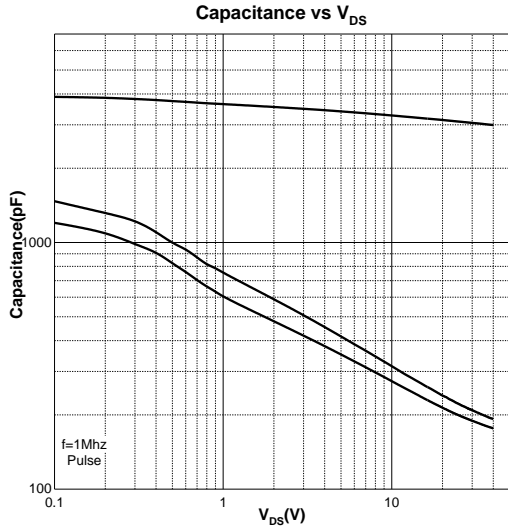

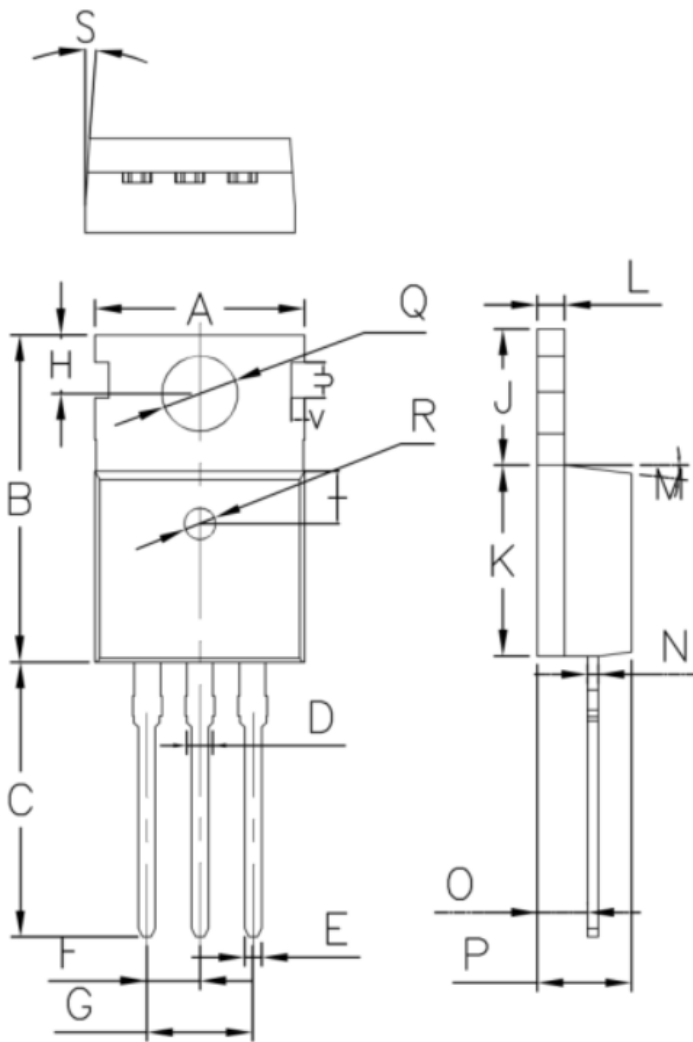
TO-220-3L-C Package Information

Symbol	Min	Non	Max
A	9.80	10.00	10.20
B	15.40	15.60	15.80
C	13.02	13.37	13.72
D	1.18	1.31	1.44
E	0.70	0.80	0.90
F	2.42	2.54	2.66
G	4.84	5.08	5.32
H	2.73	2.80	2.87
I	2.40	2.50	2.60
J	6.40	6.50	6.60
K	9.00	9.10	9.20
L	1.29	1.30	1.32
M	6.5°	7.0°	7.5°
N	0.48	0.50	0.56
O	2.35	2.4	2.5
P	4.4	4.5	4.7
Q	3.5	3.6	3.7
R	1.3	1.4	1.5
S	2°	2.5°	3°
U	1.65	1.75	1.85
V	0.58	0.68	0.78