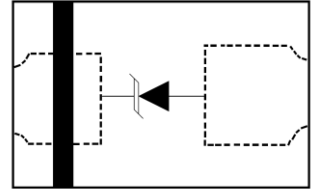

Product Summary

The GESDP8V0Y1 is designed to protect voltage sensitive electronic components from ESD and other transients. Excellent clamping capability, low leakage, low capacitance, and fast response time provide best in class protection on designs that are exposed to ESD.

The combination of small size, low capacitance, and high level of ESD protection makes them a flexible solution for applications such as HDMI, Display Port™, and MDDI interfaces. It is designed to replace multiplayer varistors (MLV) in consumer equipment applications such as mobile phone, notebook, PAD, STB, LCD TV etc.

DFN1006-2L

Feature

- Low reverse stand-off voltage: 8V
- Low capacitance
- Low reverse clamping voltage
- Low leakage current
- Fast response time
- JESD22-A114-B ESD Rating of class 3B per human body model
- IEC 61000-4-2 Level 4 ESD protection

Application

- Computers and peripherals
- Portable electronics
- High speed data lines
- Audio and video equipment
- Cellular handsets and accessories
- Other electronics equipment communication systems

Marking: LC

Absolute Maximum Ratings ($T_a=25^{\circ}\text{C}$ unless otherwise noted)

Parameter	Symbol	Value	Unit
IEC 61000-4-2 ESD Voltage	$V_{\text{ESD}}^{1)}$	± 30	kV
IEC 61000-4-2 ESD Voltage		± 30	
JESD22-A114-B ESD Voltage		± 16	
ESD Voltage		± 0.4	
Peak Pulse Power	$P_{\text{PP}}^{2)}$	234	W
Peak Pulse Current	$I_{\text{PP}}^{2)}$	13	A
Lead Solder Temperature – Maximum (10 Second Duration)	T_L	260	$^{\circ}\text{C}$
Junction Temperature	T_j	150	$^{\circ}\text{C}$
Storage Temperature	T_{stg}	-55~ +150	$^{\circ}\text{C}$

- 1) Device stressed with ten non-repetitive ESD pulses.
- 2) Non-repetitive current pulse 8/20 μs exponential decay waveform according to IEC61000-4-5.

ESD standards compliance

IEC61000-4-2 Standard

Contact Discharge		Air Discharge	
Level	Test Voltage kV	Level	Test Voltage kV
1	2	1	2
2	4	2	4
3	6	3	8
4	8	4	15

JESD22-A114-B Standard

ESD Class	Human Body Discharge V
0	0~249
1A	250~499
1B	500~999
1C	1000~1999
2	2000~3999
3A	4000~7999
3B	8000~15999

Contact discharge current waveform per IEC61000-4-2

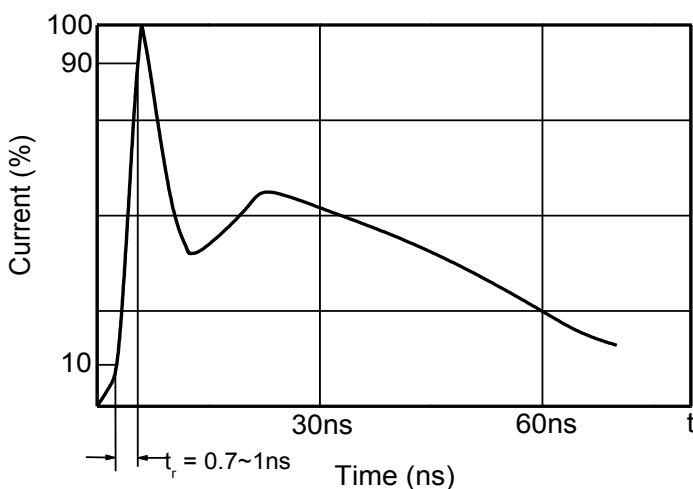

8/20 μs waveform per IEC61000-4-5

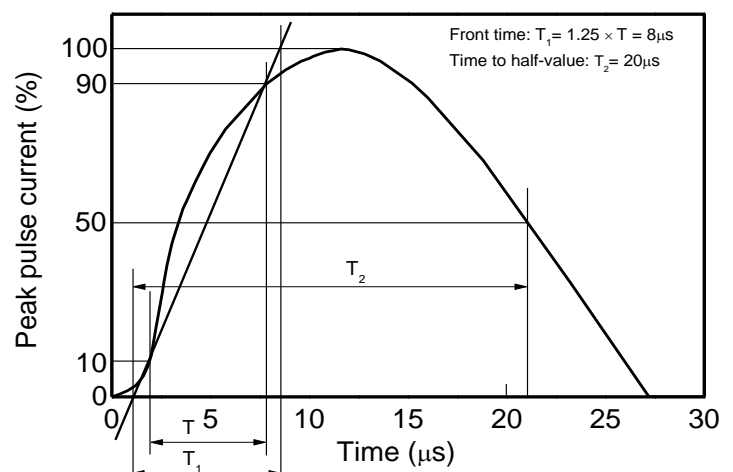

Electrical Parameter

Symbol	Parameter
V _C	Clamping Voltage @ I _{PP}
I _{PP}	Peak Pulse Current
V _{BR}	Breakdown Voltage @ I _T
I _T	Test Current
I _R	Reverse Leakage Current @ V _{RWM}
V _{RWM}	Reverse Standoff Voltage

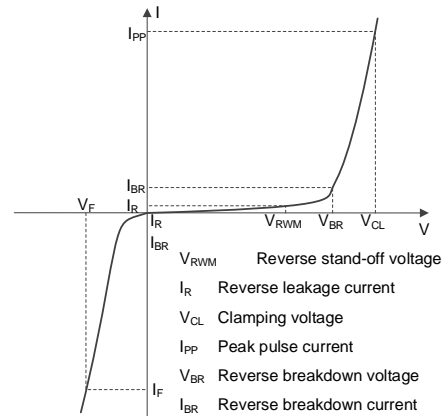

V-I characteristics for a Uni-directional TVS

Electrical Characteristics (T_a=25°C unless otherwise specified)

Parameter	Symbol	Test conditions	Min	Typ	Max	Unit
Reverse stand-off voltage	V _{RWM} ¹⁾				8	V
Reverse leakage current	I _R	V _{RWM} =8V			1	uA
Breakdown voltage	V _{BR}	I _T =1mA	9.2	10		V
Forward voltage	V _F	I _F =15mA		0.8	1.2	V
Clamping voltage	V _C ²⁾	I _{PP} =1A		11		V
		I _{PP} =13A		15	18	V
Junction capacitance	C _J	V _R =0V, f=1MHz		95	110	pF

- 1) Other voltages available upon request.
- 2) Non-repetitive current pulse 8/20μs exponential decay waveform according to IEC61000-4-5

Typical Characteristics

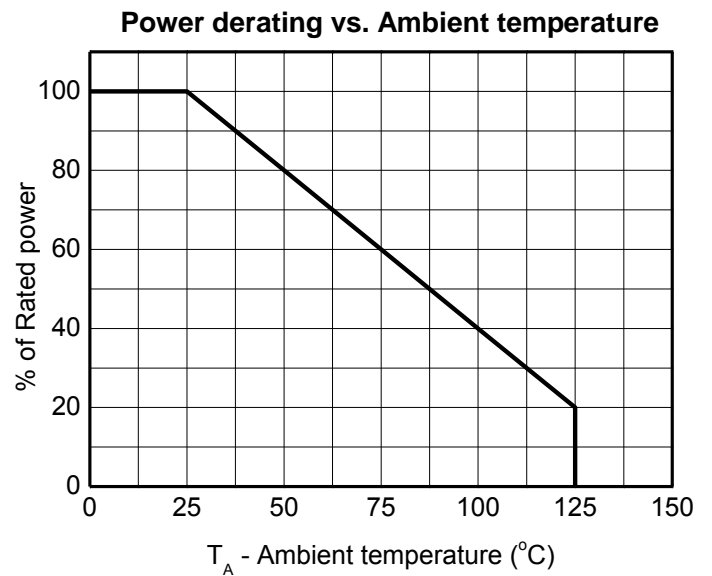
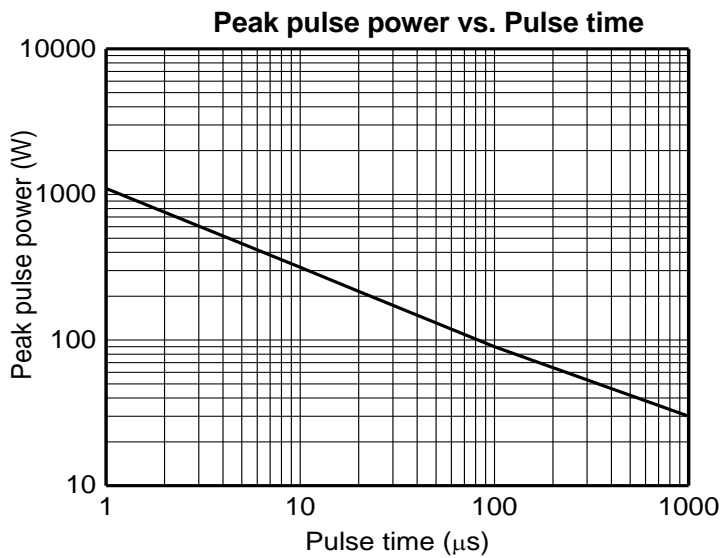
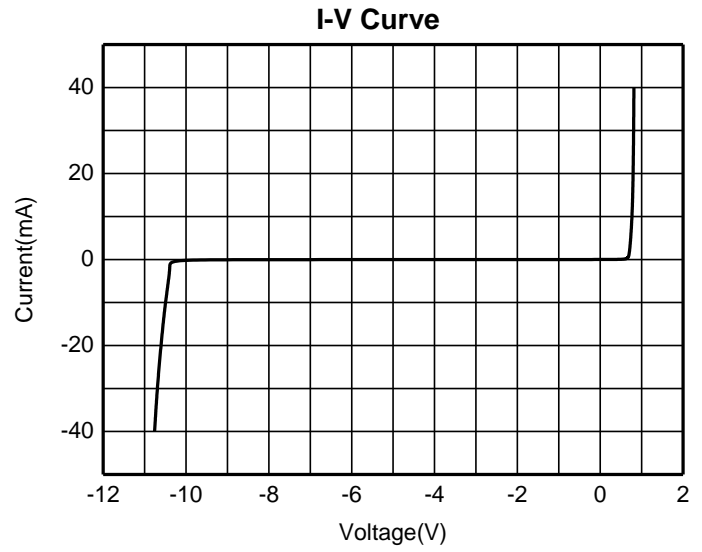
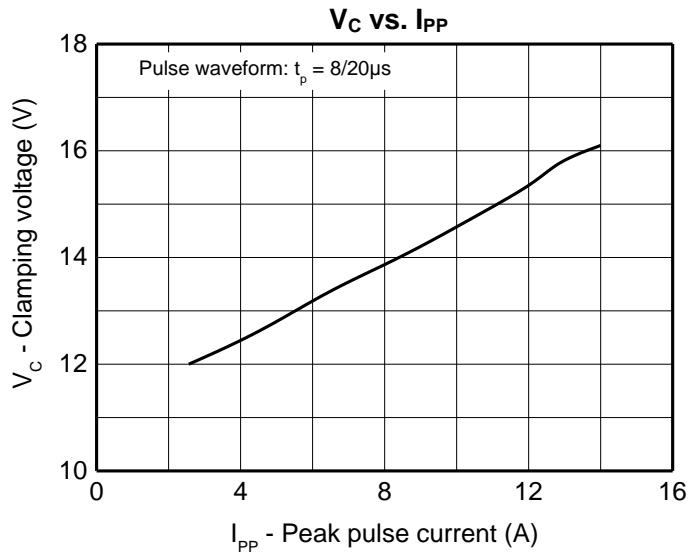

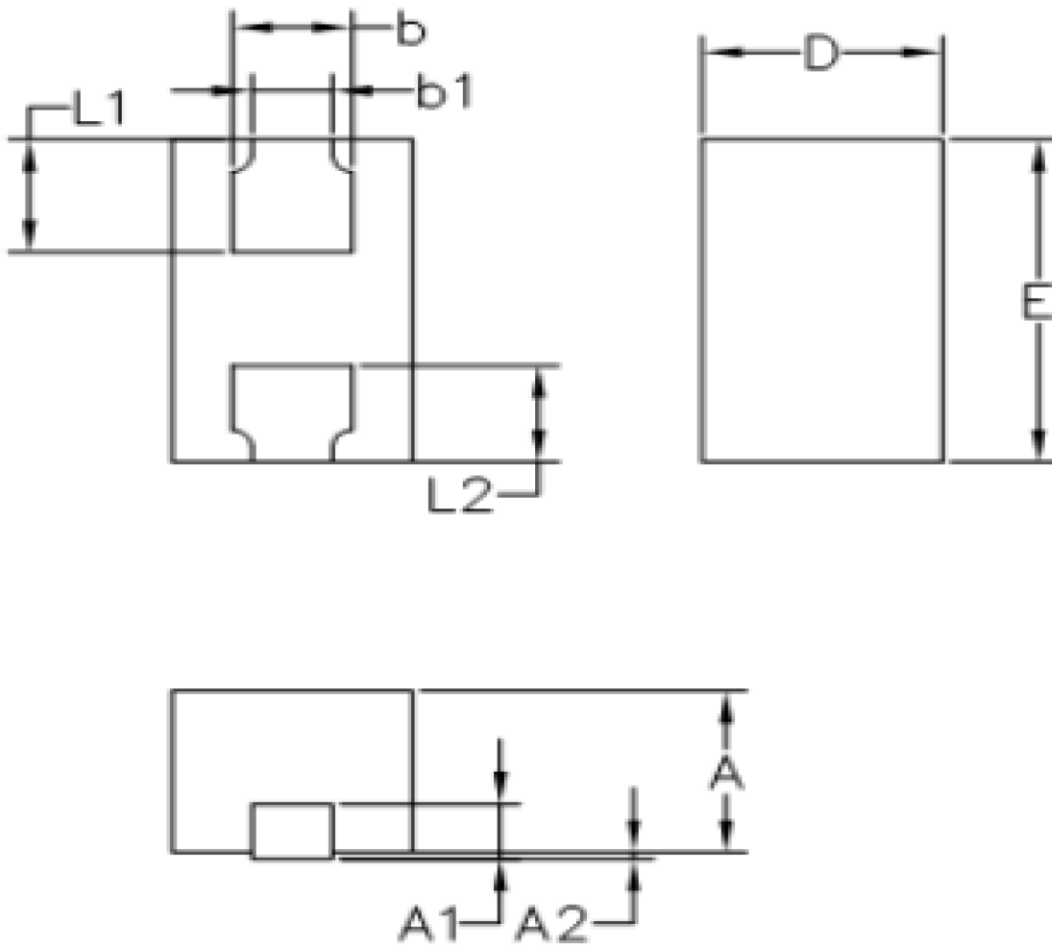
DFN1006-2L Package Outline Dimensions

	Dimensions In Millimeters		
	Min.	Typ.	Max.
D	0.55	0.60	0.68
E	0.95	1.00	1.08
L1	0.30	0.35	0.40
L2	0.25	0.30	0.35
A	0.45	0.50	0.55
A1	0.15 REF		
A2	0.00		0.05
b	0.25	0.30	0.35
b1	0.15	0.20	0.25