

GP7808X
Feature

- Output Voltage: 8V
- Maximum Output Current: 1.5A
- Output Transition Safe-Area Compensation

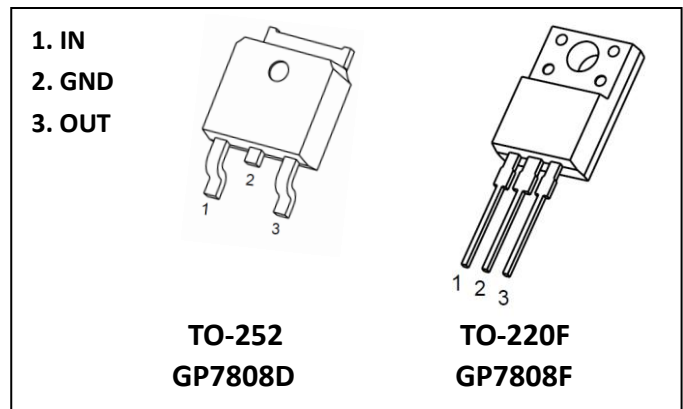

Absolute Maximum Ratings ($T_a=25^{\circ}\text{C}$ unless otherwise noted)

Parameter	Symbol	Value	Unit
Input voltage	V_i	35	V
Thermal Resistance from Junction to Air(TO-252)	$R_{\theta JA}$	80	$^{\circ}\text{C/W}$
Thermal Resistance from Junction to Air(TO-220F)	$R_{\theta JA}$	66.7	$^{\circ}\text{C/W}$
Operating Junction Temperature Range	T_{OPR}	-25~+125	$^{\circ}\text{C}$
Storage Temperature Range	T_{STG}	-65~+150	$^{\circ}\text{C}$

Electrical Characteristics($T_a=25^{\circ}\text{C}$, $V_i=10\text{V}$, $I_o=500\text{mA}$, $C_i=0.33\mu\text{F}$, $C_o=0.1\mu\text{F}$, unless otherwise specified)

Parameter	Symbol	Test Condition	Min	Type	Max	Unit	
Output voltage	V_o	$I_o=500\text{mA}$	25°C	7.7	8.0	8.3	V
		$10.5\text{V}\leq V_i\leq 23\text{V}$, $I_o=5\text{mA}-1\text{A}$	$-25-125^{\circ}\text{C}$	7.6	8.0	8.4	V
Load Regulation	ΔV_o	$I_o=5\text{mA}-1.5\text{A}$	25°C		12	160	mV
		$I_o=250\text{mA}-750\text{mA}$	25°C		4	80	mV
Line regulation	ΔV_o	$10.5\text{V}\leq V_i\leq 25\text{V}$	25°C		6	160	mV
		$11\text{V}\leq V_i\leq 17\text{V}$	25°C		2	80	mV
Quiescent Current	I_Q	$V_i=10\text{V}$, $I_o=500\text{mA}$	25°C		4.3	8	mA
Quiescent Current Change	ΔI_Q	$10.5\text{V}\leq V_i\leq 25\text{V}$	$-25-125^{\circ}\text{C}$			1	mA
		$5\text{mA}\leq I_o\leq 1\text{A}$	$-25-125^{\circ}\text{C}$			0.5	mA
Output Voltage Drift	$\Delta V_o/\Delta T$	$I_o=5\text{mA}$	$-25-125^{\circ}\text{C}$		-0.8		$\text{mV}/^{\circ}\text{C}$
Ripple Rejection	RR	$11.5\text{V}\leq V_i\leq 21.5\text{V}$, $f\leq 120\text{KHz}$	$-25-125^{\circ}\text{C}$	55	72		dB
Output Noise Voltage	V_N	$10\text{Hz}\leq f\leq 100\text{KHz}$	25°C		52		$\mu\text{V}/V_o$
Dropout Voltage	V_d	$I_o=1\text{A}$	25°C		2		V
Output Resistance	R_o	$f=1\text{KHz}$	25°C		10		m Ω
Short Circuit Current	I_{sc}		25°C		450		mA
Peak Current	I_{pk}		25°C		2.2		A

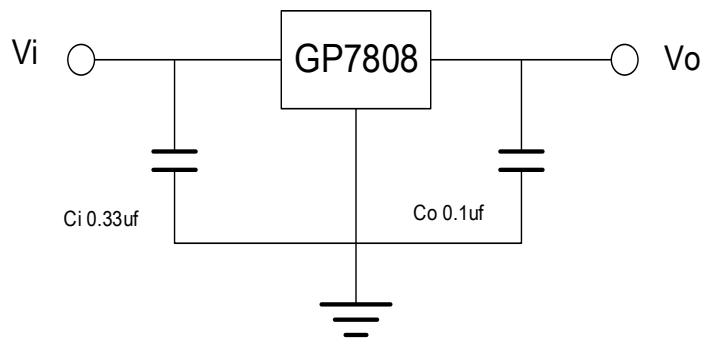
Typical Application



Typical Characteristics

Output Characteristics

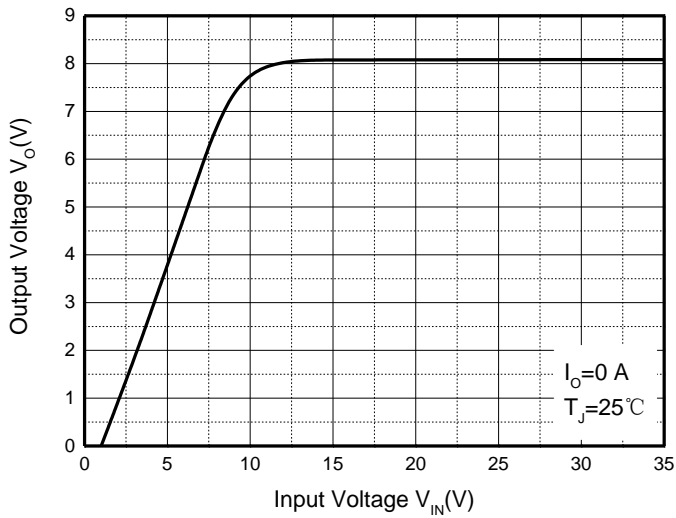

Output Characteristics

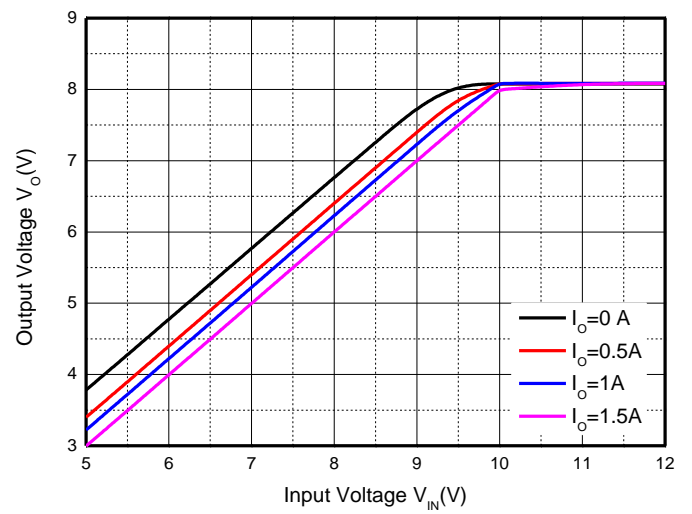

Quiescent Current

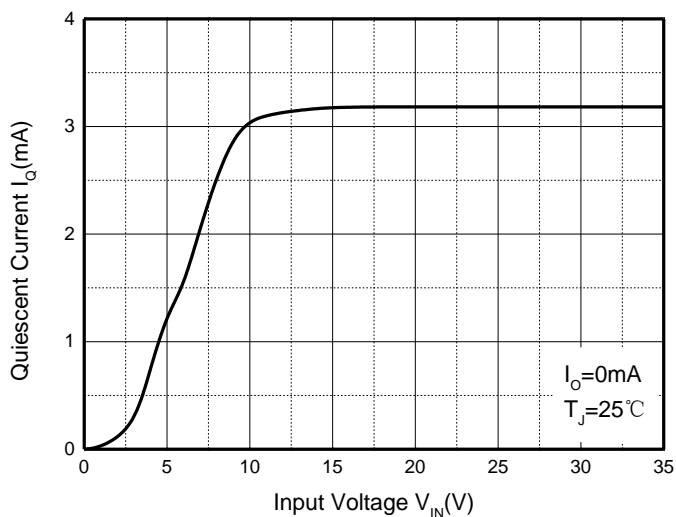

Current Cut-off Grid Voltage

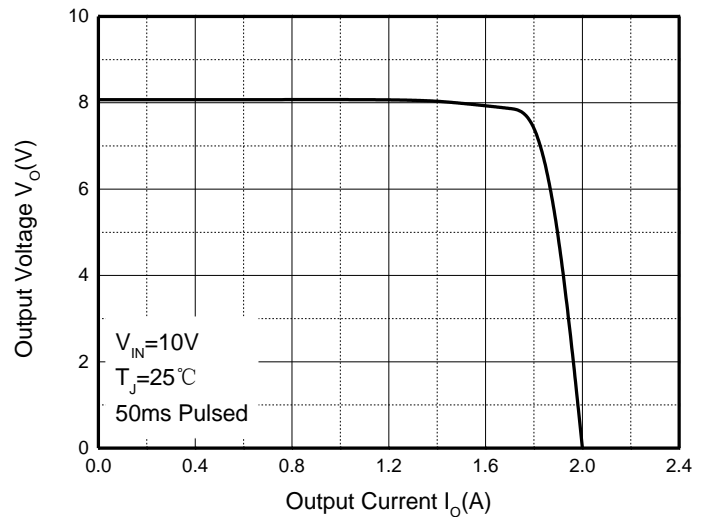

Output Voltage vs Junction Temperature

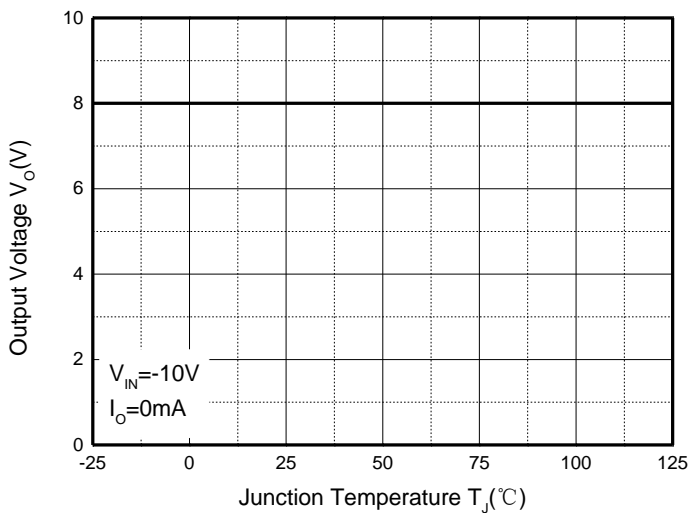

Power Derating Curve

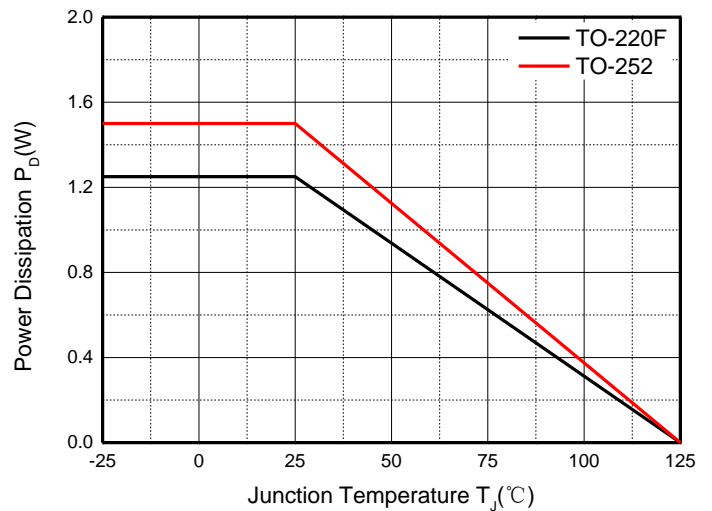

TO-252 Package Outline Dimensions

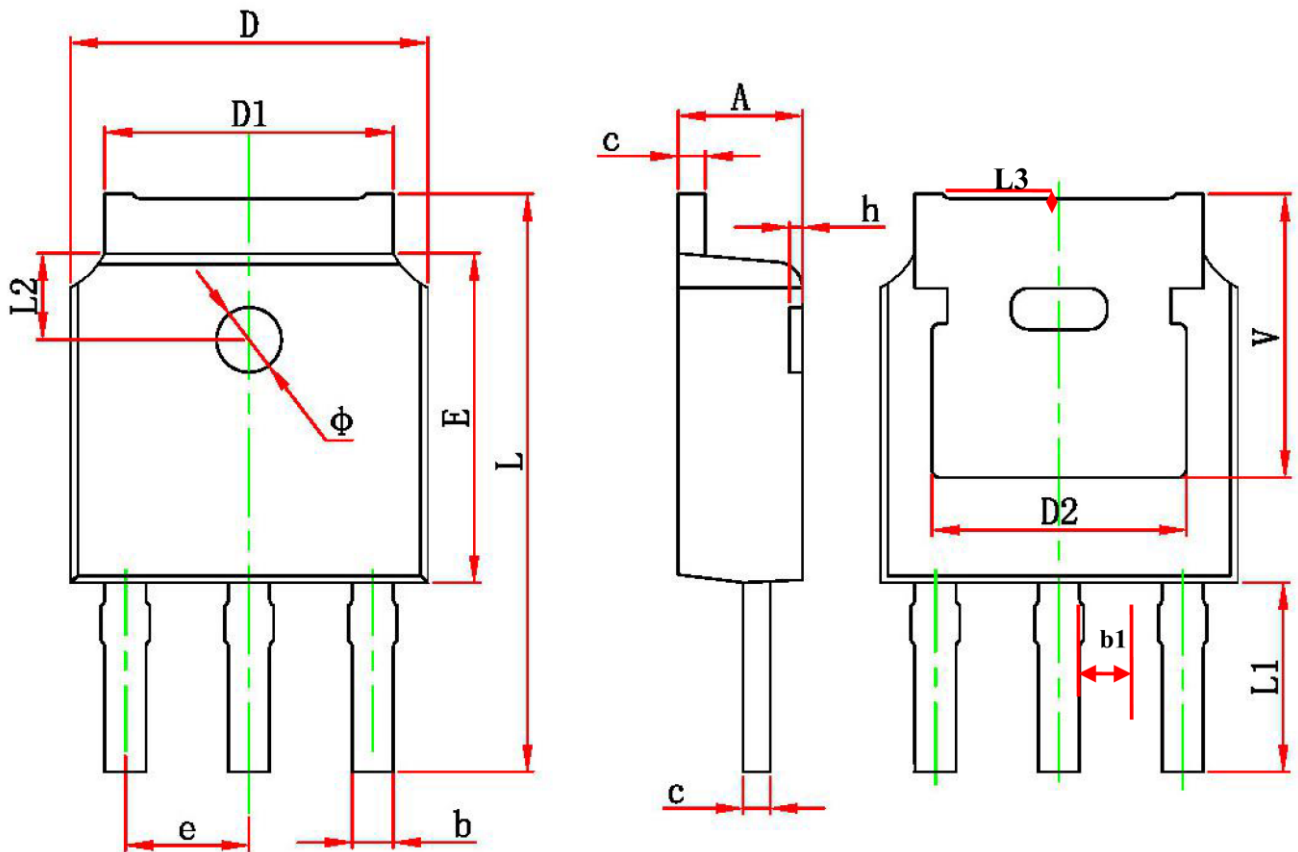

SYMBOL	MIN	MAX	SYMBOL	MIN	MAX
A	2.2	2.4	L1	2.90 REF	
A1	0	0.125	L2	1.4	1.7
b	0.66	0.86	L3	1.60 REF	
c	0.46	0.58	L4	0.6	1
D	6.5	6.7	φ	1.1	1.3
D1	5.1	5.46	θ	0°	8°
D2	4.830 REF		h	0	0.3
E	6	6.2	V	5.35 REF	
e	2.186	2.386			
L	9.8	10.4			
共面度	0	0.09			

单位: mm

TO-220F Package Outline Dimensions

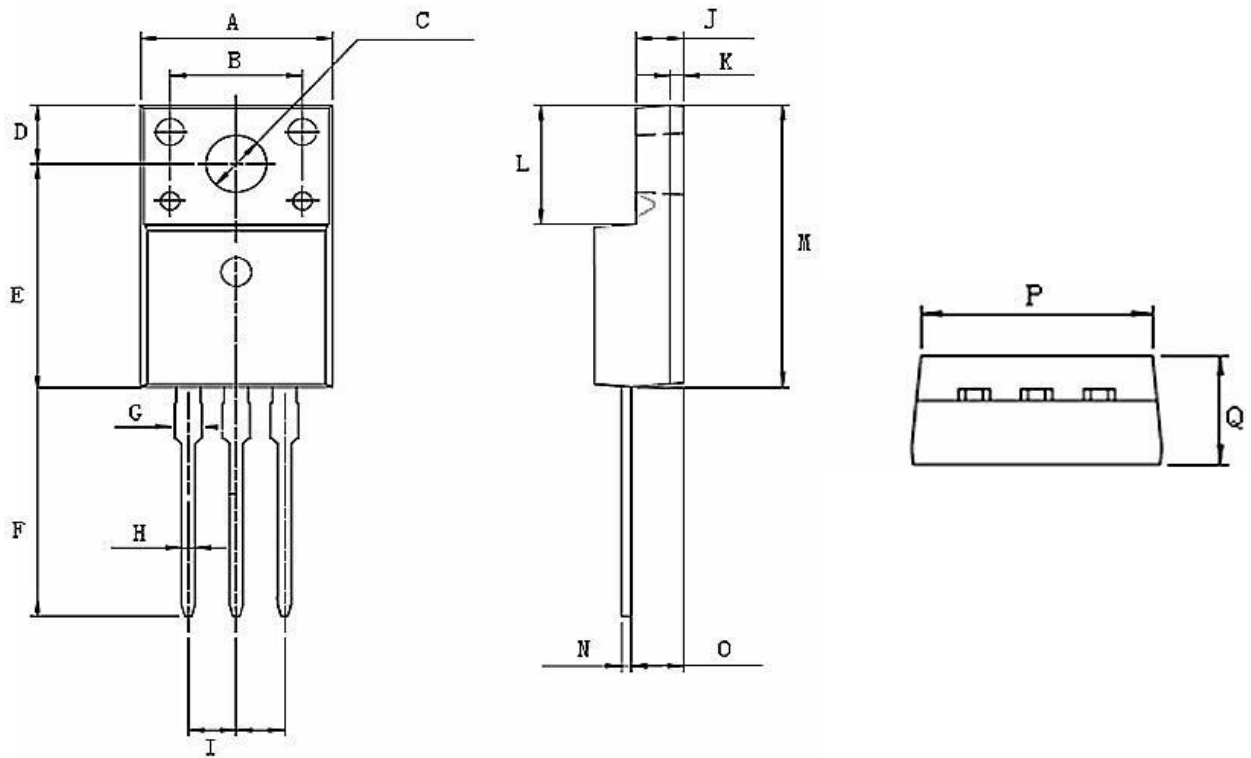

SYMBOL	MIN	MAX	SYMBOL	MIN	MAX
A	9.92	10.32	K	0.55	0.75
B	6.9	7.1	L	6.57	6.77
C	3.35	3.55	M	15.8	16
D	3.25	3.35	N	0.4	0.6
E	12.35	12.75	O	2.62	2.92
F	12.8	13.2	P	9.2	9.4
G	1.22	1.42	Q	4.6	4.8
H	0.7	0.9			
I	2.54 Typ				
J	2.45	2.65			

单位: mm