



#### Product Summary

$V_{(BR)DSS}$	$R_{DS(on)TYP}$	$I_D$
50V	0.9Ω@10V	0.34A
	1.0Ω@4.5V	

#### Feature

- High density cell design for extremely low  $R_{DS(on)}$
- Rugged and Reliable

#### Application

- Direct Logic-Level Interface: TTL/CMOS
- Drivers: Relays, Solenoids, Lamps, Hammers, Display, Memories, Transistors, etc.
- Battery Operated Systems
- Solid-State Relays

#### MARKING:

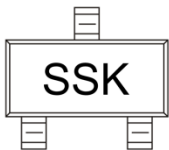

#### SOT-23

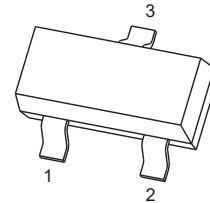

1. GATE
2. SOURCE
3. DRAIN

#### Schematic diagram

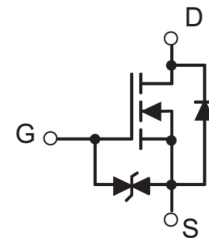

#### ABSOLUTE MAXIMUM RATINGS ( $T_a=25^\circ\text{C}$ unless otherwise noted)

Parameter	Symbol	Value	Unit
Drain-Source Voltage	$V_{DS}$	50	V
Gate-Source Voltage	$V_{GS}$	$\pm 20$	
Continuous Drain Current	$I_D$	0.34	A
Power Dissipation	$P_D$	0.35	W
Thermal Resistance from Junction to Ambient	$R_{\theta JA}$	357	$^\circ\text{C/W}$
Junction Temperature	$T_J$	150	$^\circ\text{C}$
Storage Temperature	$T_{STG}$	-55~ +150	

## MOSFET ELECTRICAL CHARACTERISTICS( $T_a=25^{\circ}\text{C}$ unless otherwise noted)

Parameter	Symbol	Test Condition	Min	Type	Max	Unit
<b>Static Characteristics</b>						
Drain-source breakdown voltage	$V_{(BR)DSS}$	$V_{GS} = 0V, I_D = 250\mu A$	50			V
Zero gate voltage drain current	$I_{DSS1}$	$V_{DS} = 50V, V_{GS} = 0V$			0.5	$\mu A$
	$I_{DSS2}$	$V_{DS} = 30V, V_{GS} = 0V$			100	nA
Gate-body leakage current	$I_{GSS}$	$V_{GS} = \pm 20V, V_{DS} = 0V$			$\pm 10$	$\mu A$
Gate threshold voltage <sup>1</sup>	$V_{GS(th)}$	$V_{DS} = V_{GS}, I_D = 250\mu A$	0.8	1.1	1.5	V
Drain-source on-resistance <sup>1</sup>	$R_{DS(on)}$	$V_{GS} = 10V, I_D = 0.22A$		0.9	2.5	$\Omega$
		$V_{GS} = 4.5V, I_D = 0.22A$		1.0	6.0	
Forward transconductance <sup>1</sup>	$g_{FS}$	$V_{DS} = 10V, I_D = 0.22A$		0.13		S
<b>Dynamic characteristics<sup>2</sup></b>						
Input Capacitance	$C_{iss}$	$V_{DS} = 25V, V_{GS} = 0V, f = 1MHz$		26.5		pF
Output Capacitance	$C_{oss}$			12.9		
Reverse Transfer Capacitance	$C_{rss}$			5.9		
<b>Switching Characteristics<sup>1,2</sup></b>						
Turn-on delay time	$t_{d(on)}$	$V_{DD} = 30V, I_D = 0.29A,$ $V_{GS} = 10V, R_G = 6\Omega$			5	nS
Turn-on rise time	$t_r$				18	
Turn-off delay time	$t_{d(off)}$				36	
Turn-off fall time	$t_f$				14	
<b>Source-Drain Diode characteristics<sup>1</sup></b>						
Diode Forward voltage	$V_{SD}$	$I_S = 0.44A, V_{GS} = 0V$		1.15	1.4	V

### Notes:

1. Pulse Test ; Pulse Width  $\leq 300\mu s$ , Duty Cycle  $\leq 2\%$ .
2. These parameters have no way to verify.

**Typical Electrical and Thermal Characteristics**

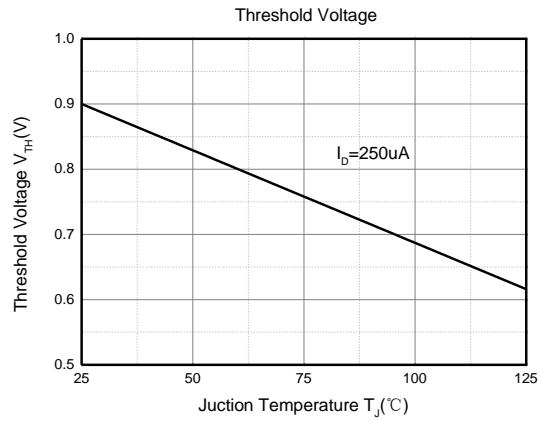
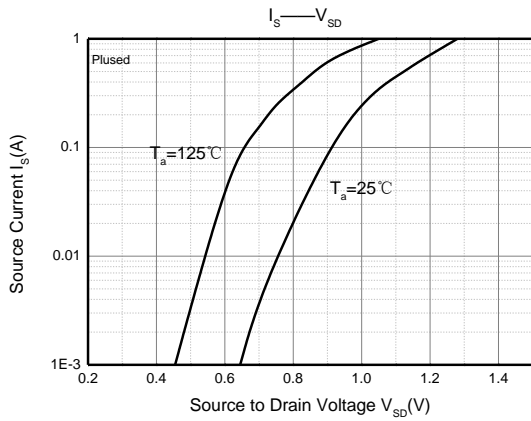
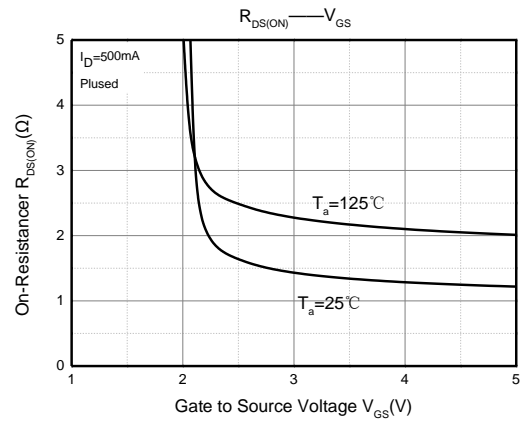
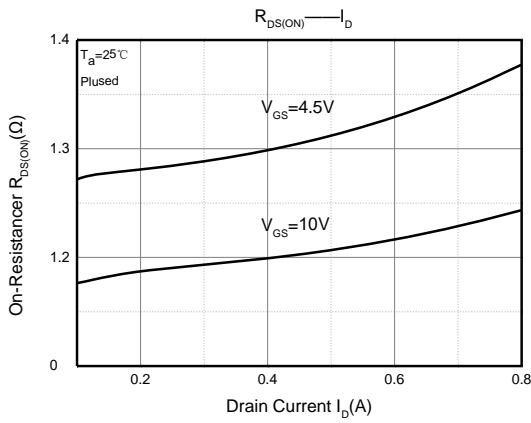
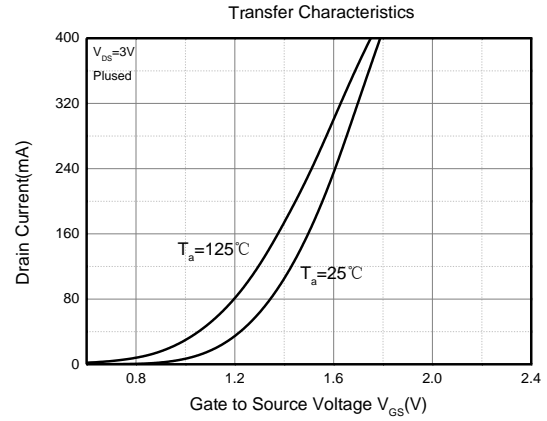
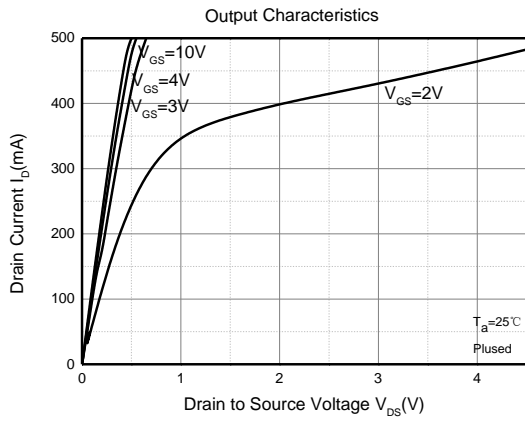

## SOT-23 Package Information

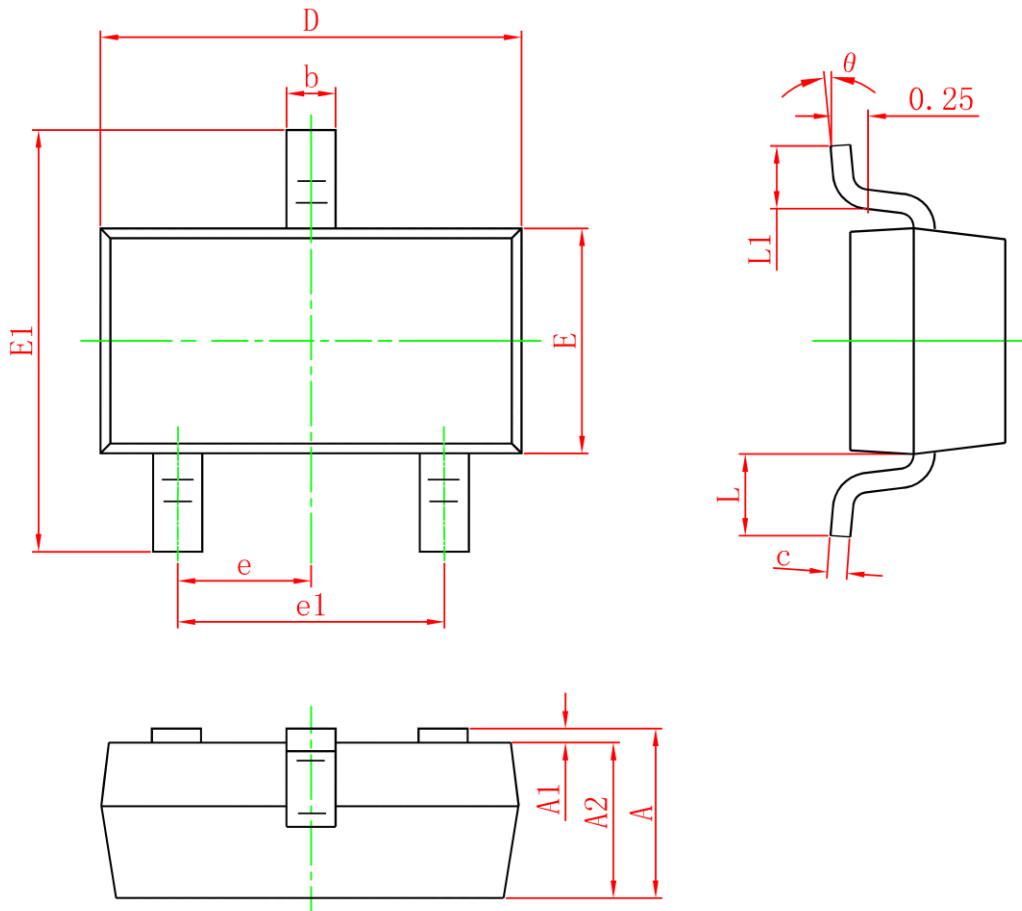

Symbol	Dimensions In Millimeters		Dimensions In Inches	
	Min.	Max.	Min.	Max.
A	0.900	1.150	0.035	0.045
A1	0	0.100	0	0.004
A2	0.900	1.050	0.035	0.041
b	0.300	0.500	0.012	0.020
c	0.080	0.150	0.003	0.006
D	2.800	3.000	0.110	0.118
E	1.150	1.500	0.045	0.059
E1	2.250	2.650	0.089	0.104
e	0.950TYP		0.037TYP	
e1	1.800	2.000	0.071	0.079
L	0.550REF		0.022REF	
L1	0.300	0.500	0.012	0.020
$\theta$	0°	8°	0°	8°