



#### Product Summary

$V_{(BR)DSS}$	$R_{DS(on)TYP}$	$I_D$
20V	47mΩ@4.5V	2.5A
	64mΩ@2.5V	

#### Feature

- Trench Technology Power MOSFET
- Low  $R_{DS(ON)}$
- Low Gate Charge

#### Application

- Load Switch
- DC/DC Converter

#### MARKING:

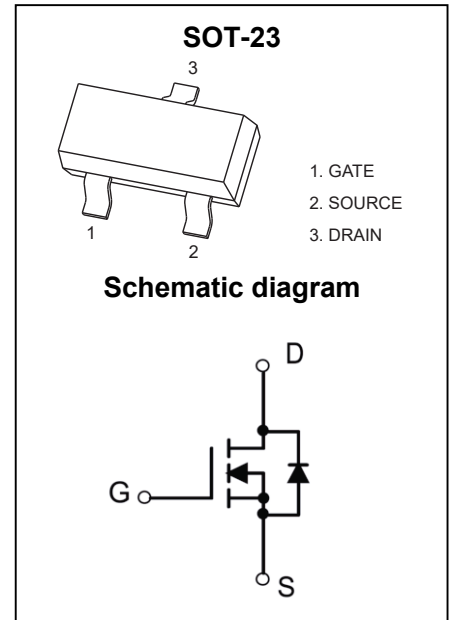
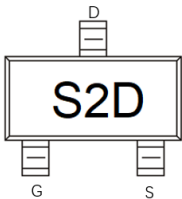

#### ABSOLUTE MAXIMUM RATINGS ( $T_A = 25^\circ\text{C}$ unless otherwise noted)

Parameter	Symbol	Value	Unit
Drain - Source Voltage	$V_{DS}$	20	V
Gate - Source Voltage	$V_{GS}$	$\pm 10$	V
Continuous Drain Current <sup>1,5</sup>	$I_D$	2.5	A
Pulsed Drain Current <sup>2</sup>	$I_{DM}$	10	A
Power Dissipation <sup>4,5</sup>	$P_D$	0.5	W
Thermal Resistance from Junction to Ambient <sup>5</sup>	$R_{\theta JA}$	220	$^\circ\text{C/W}$
Junction Temperature	$T_J$	150	$^\circ\text{C}$
Storage Temperature	$T_{STG}$	-55~ +150	$^\circ\text{C}$

**MOSFET ELECTRICAL CHARACTERISTICS ( $T_J = 25^\circ\text{C}$  unless otherwise noted)**

Parameter	Symbol	Test Condition	Min	Type	Max	Unit
<b>Off Characteristics</b>						
Drain - Source Breakdown Voltage	$V_{(BR)DSS}$	$V_{GS} = 0V, I_D = 250\mu A$	20			V
Zero Gate Voltage Drain Current	$I_{DSS}$	$V_{DS} = 20V, V_{GS} = 0V$			1	$\mu A$
Gate - Body Leakage Current	$I_{GSS}$	$V_{GS} = \pm 10V, V_{DS} = 0V$			$\pm 100$	nA
<b>On Characteristics<sup>3</sup></b>						
Gate Threshold Voltage	$V_{GS(th)}$	$V_{DS} = V_{GS}, I_D = 250\mu A$	0.4	0.7	1.1	V
Drain-source On-resistance	$R_{DS(on)}$	$V_{GS} = 4.5V, I_D = 2A$		47	60	m $\Omega$
		$V_{GS} = 2.5V, I_D = 1A$		64	80	
<b>Dynamic Characteristics</b>						
Input Capacitance	$C_{iss}$	$V_{DS} = 10V, V_{GS} = 0V, f = 1MHz$		130.7		pF
Output Capacitance	$C_{oss}$			25.8		
Reverse Transfer Capacitance	$C_{rss}$			24.5		
Gate Resistance	$R_g$	$V_{DS} = 0V, V_{GS} = 0V, f = 1MHz$		7.7		$\Omega$
<b>Switching Characteristics</b>						
Total Gate Charge	$Q_g$	$V_{DS} = 10V, V_{GS} = 4.5V, I_D = 2A$		2.45		nC
Gate-source Charge	$Q_{gs}$			0.03		
Gate-drain Charge	$Q_{gd}$			0.53		
Turn-on Delay Time	$t_{d(on)}$	$V_{DD} = 10V, V_{GS} = 4.5V,$ $I_D = 2.5A, R_G = 3\Omega$		3		ns
Turn-on Rise Time	$t_r$			29		
Turn-off Delay Time	$t_{d(off)}$			6		
Turn-off Fall Time	$t_f$			22		
<b>Source - Drain Diode Characteristics</b>						
Diode Forward Voltage <sup>3</sup>	$V_{SD}$	$V_{GS} = 0V, I_S = 0.94A$			1.2	V

**Notes :**

- 1.The maximum current rating is limited by package.
- 2.Pulse Test : Pulse Width  $\leq 10\mu s$ , duty cycle  $\leq 1\%$ .
- 3.Pulse Test : Pulse Width  $\leq 300\mu s$ , duty cycle  $\leq 2\%$ .
- 4.The power dissipation  $P_D$  is limited by  $T_{J(MAX)} = 150^\circ\text{C}$ .
- 5.Device mounted on 1in<sup>2</sup> FR-4 board with 2oz. Copper, in a still air environment with  $T_A = 25^\circ\text{C}$ .

**Typical Characteristics**

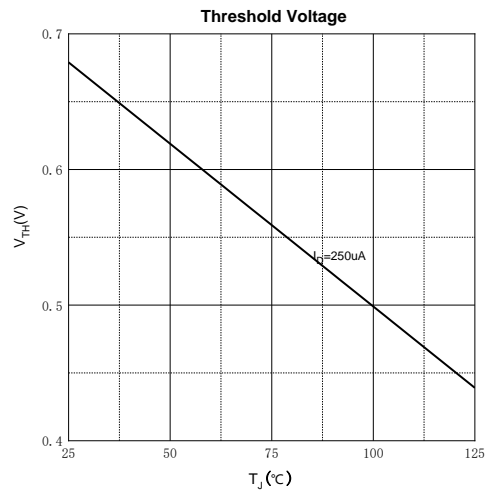
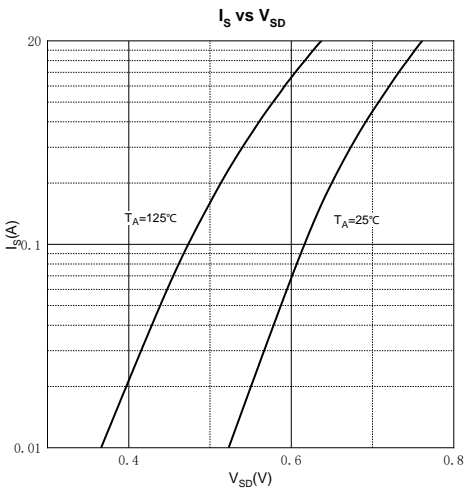
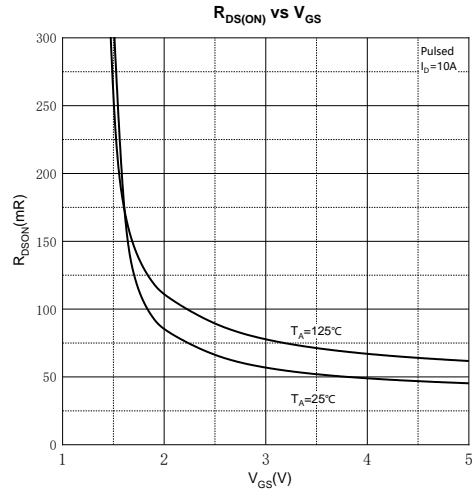
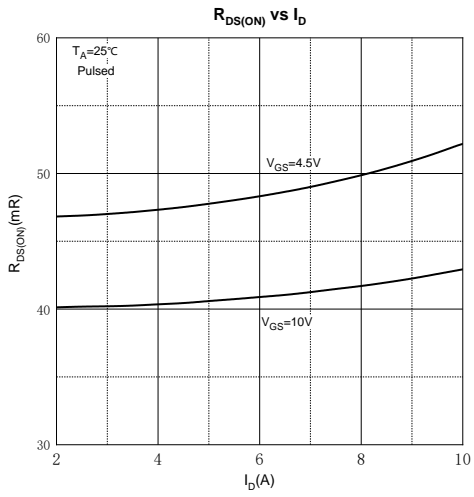
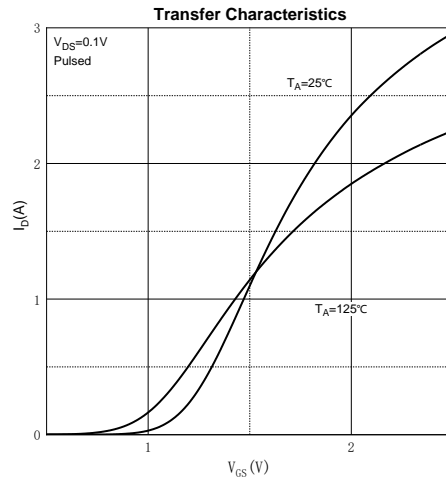
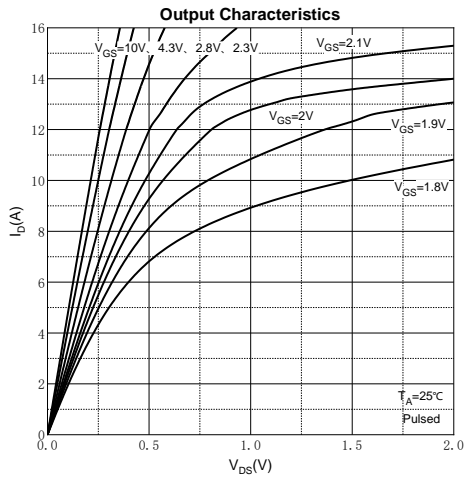

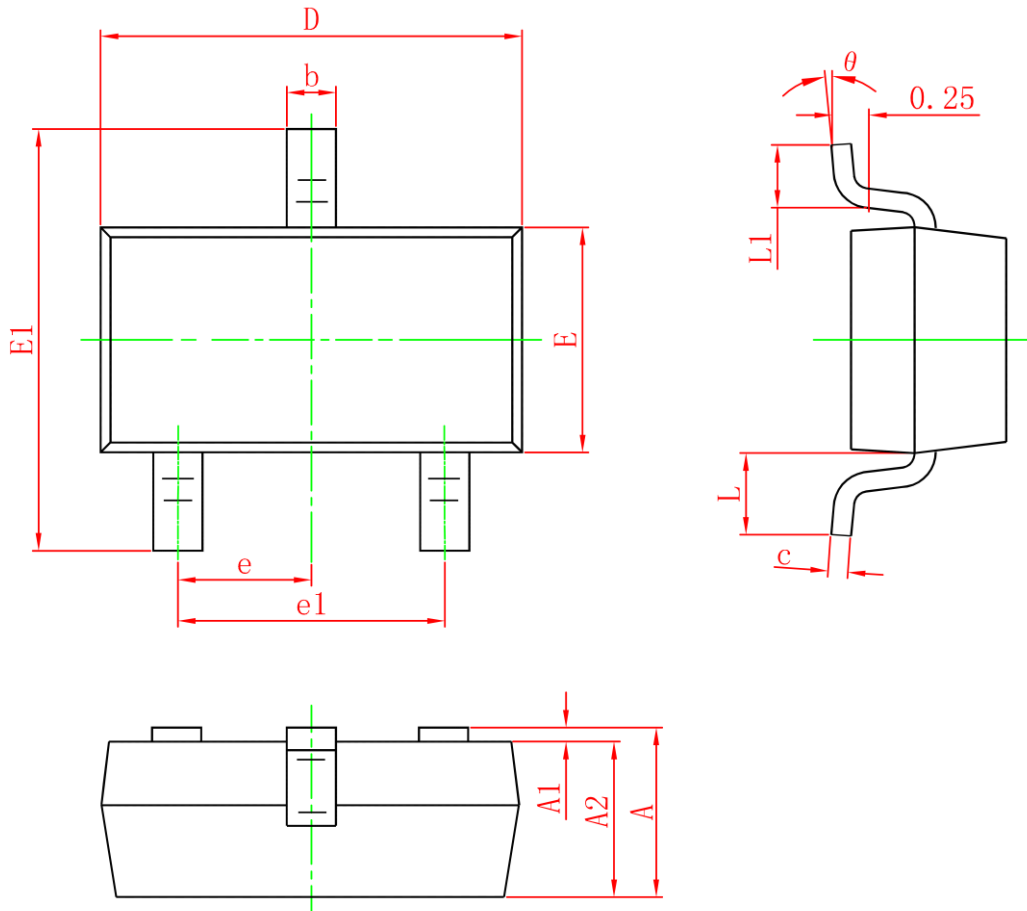
**SOT-23 Package Information**

Symbol	Dimensions In Millimeters		Dimensions In Inches	
	Min.	Max.	Min.	Max.
A	0.900	1.150	0.035	0.045
A1	0	0.100	0	0.004
A2	0.900	1.050	0.035	0.041
b	0.300	0.500	0.012	0.020
c	0.080	0.150	0.003	0.006
D	2.800	3.000	0.110	0.118
E	1.150	1.500	0.045	0.059
E1	2.250	2.650	0.089	0.104
e	0.950TYP		0.037TYP	
e1	1.800	2.000	0.071	0.079
L	0.550REF		0.022REF	
L1	0.300	0.500	0.012	0.020
$\theta$	0°	8°	0°	8°