



#### Product Summary

$V_{(BR)DSS}$	$R_{DS(on)TYP}$	$I_D$
-20V	33mΩ@-4.5V	-4A
	45mΩ@-2.5V	
	63mΩ@-1.8V	

#### Feature

- Excellent  $R_{DS(ON)}$ , low gate charge, low gate voltages
- TrenchFET power MOSFET
- ESD protected gate

#### Application

- Load switch and in PWM applications

#### MARKING:

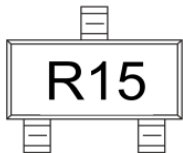

#### SOT-23

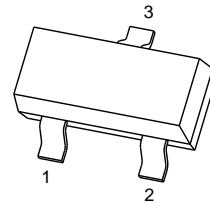

1. GATE
2. SOURCE
3. DRAIN

#### Schematic diagram

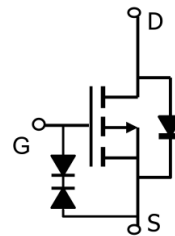

#### ABSOLUTE MAXIMUM RATINGS ( $T_a=25^{\circ}\text{C}$ unless otherwise noted)

Parameter	Symbol	Value	Unit
Drain-Source Voltage	$V_{DS}$	-20	V
Gate-Source Voltage	$V_{GS}$	$\pm 10$	V
Continuous Drain Current ( $t \leq 10\text{s}$ )	$I_D$	-4.0	A
Maximum Power Dissipation ( $t \leq 10\text{s}$ )	$P_D$	0.35	W
Thermal Resistance from Junction to Ambient	$R_{\theta JA}$	357	$^{\circ}\text{C/W}$
Junction Temperature	$T_J$	150	$^{\circ}\text{C}$
Operating Temperature	$T_{OPR}$	-45~ +125	$^{\circ}\text{C}$
Storage Temperature	$T_{STG}$	-55~ +150	$^{\circ}\text{C}$

**MOSFET ELECTRICAL CHARACTERISTICS(T<sub>a</sub>=25°C unless otherwise noted)**

Parameter	Symbol	Test Condition	Min	Type	Max	Unit
<b>Static Characteristics</b>						
Drain-source breakdown voltage	V <sub>(BR)DSS</sub>	V <sub>GS</sub> = 0V, I <sub>D</sub> = -250μA	-20			V
Zero gate voltage drain current	I <sub>DSS</sub>	V <sub>DS</sub> = -16V, V <sub>GS</sub> = 0V			-1	μA
Gate-body leakage current	I <sub>GSS</sub>	V <sub>GS</sub> = ±10V, V <sub>DS</sub> = 0V			±10	μA
Gate threshold voltage	V <sub>GS(th)</sub>	V <sub>DS</sub> = V <sub>GS</sub> , I <sub>D</sub> = -250μA	-0.4	-0.65	-1.0	V
Drain-source on-resistance <sup>(1)</sup>	R <sub>DS(on)</sub>	V <sub>GS</sub> = -4.5V, I <sub>D</sub> = -4A		33	50	mΩ
		V <sub>GS</sub> = -2.5V, I <sub>D</sub> = -4A		45	60	
		V <sub>GS</sub> = -1.8V, I <sub>D</sub> = -2A		63	100	
Forward tranconductance <sup>(2)</sup>	g <sub>FS</sub>	V <sub>DS</sub> = -5V, I <sub>D</sub> = -4A	8			S
<b>Dynamic characteristics<sup>(3)</sup></b>						
Input Capacitance	C <sub>iss</sub>	V <sub>DS</sub> = -10V, V <sub>GS</sub> = 0V, f = 1MHz		794		pF
Output Capacitance	C <sub>oss</sub>			139		
Reverse Transfer Capacitance	C <sub>rss</sub>			123		
Gate resistance	R <sub>g</sub>	V <sub>DS</sub> = 0V, V <sub>GS</sub> = 0V, f = 1MHz		4.8		Ω
<b>Switching Characteristics</b>						
Turn-on delay time <sup>(3)</sup>	t <sub>d(on)</sub>	V <sub>DS</sub> = -10V, V <sub>GS</sub> = -4.5V R <sub>GEN</sub> = 3Ω, R <sub>L</sub> = 2.5Ω,		9.5		ns
Turn-on rise time <sup>(3)</sup>	t <sub>r</sub>			17		
Turn-off delay time <sup>(3)</sup>	t <sub>d(off)</sub>			94		
Turn-off fall time <sup>(3)</sup>	t <sub>f</sub>			35		
Total gate charge	Q <sub>g</sub>	V <sub>DS</sub> = -10V, V <sub>GS</sub> = -4.5V, I <sub>D</sub> = -4A		17.2		nC
Gate-source charge	Q <sub>gs</sub>			1.3		
Gate-drain charge	Q <sub>gd</sub>			4.5		
<b>Source-Drain Diode characteristics</b>						
Diode Forward voltage <sup>(2)</sup>	V <sub>DS</sub>	V <sub>GS</sub> = 0V, I <sub>S</sub> = -1A			-1	V

**Notes:**

1. Repetitive rating, pulse width limited by junction temperature.
2. Pulse Test : Pulse width ≤ 300μs, duty cycle ≤ 2%.
3. These parameters have no way to verify.

**Typical Electrical and Thermal Characteristics**

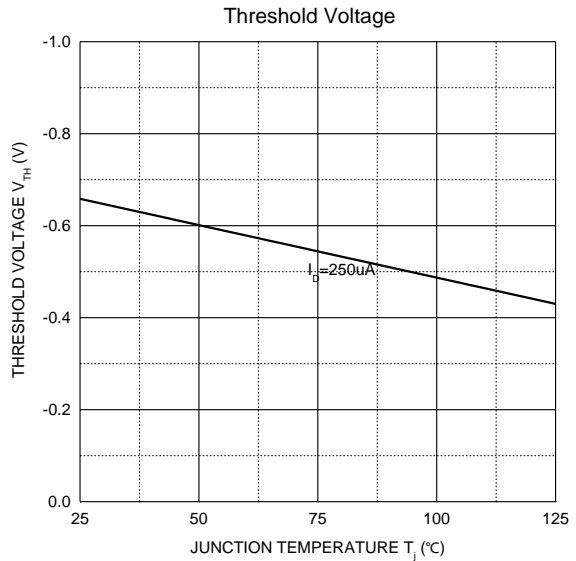
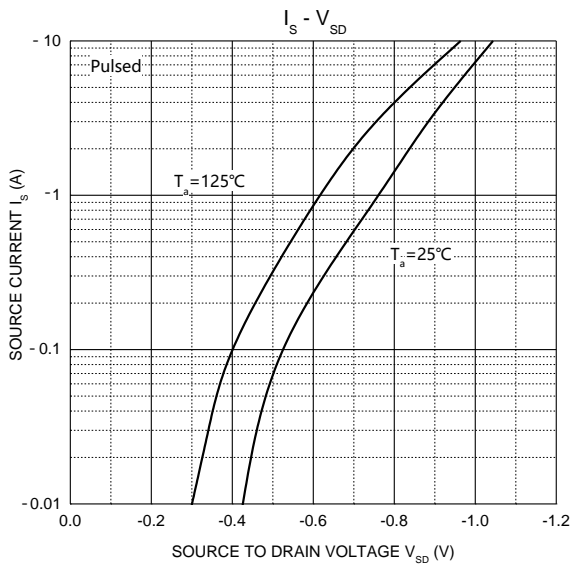
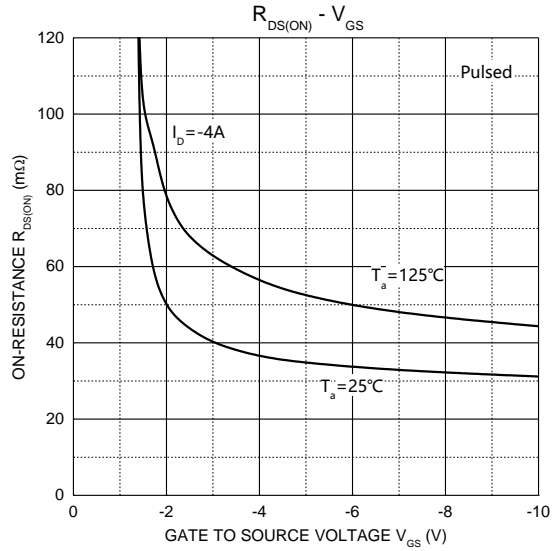
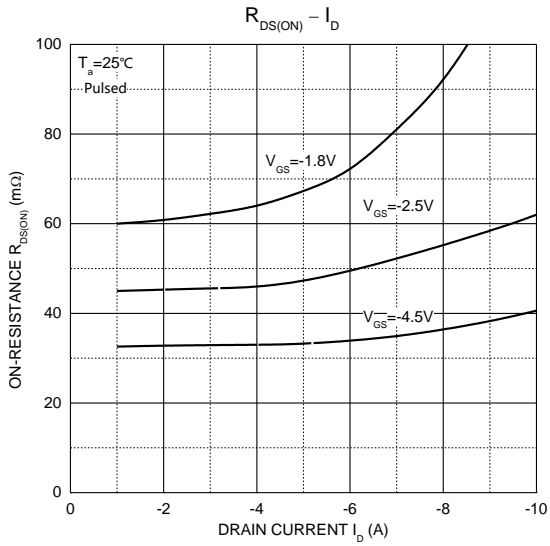
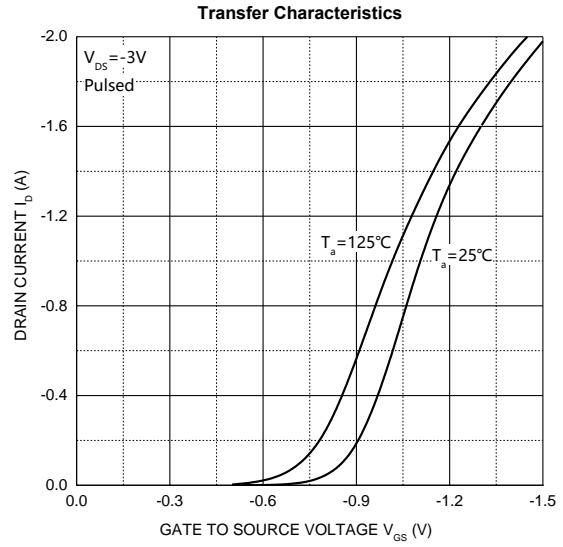
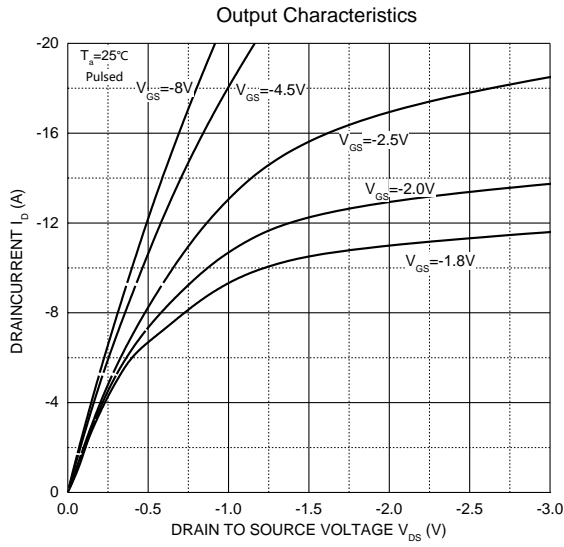

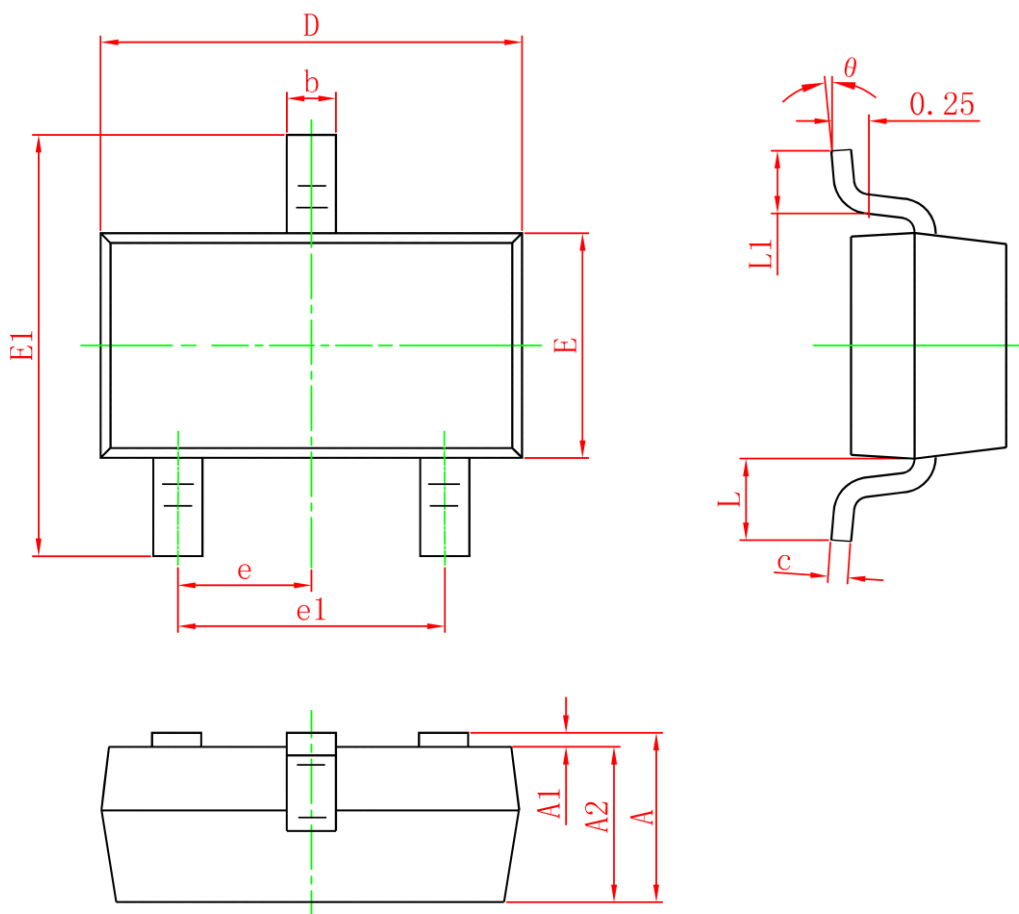
**SOT-23 Package Information**

Symbol	Dimensions In Millimeters		Dimensions In Inches	
	Min.	Max.	Min.	Max.
A	0.900	1.150	0.035	0.045
A1	0	0.100	0	0.004
A2	0.900	1.050	0.035	0.041
b	0.300	0.500	0.012	0.020
c	0.080	0.150	0.003	0.006
D	2.800	3.000	0.110	0.118
E	1.150	1.500	0.045	0.059
E1	2.250	2.650	0.089	0.104
e	0.950TYP		0.037TYP	
e1	1.800	2.000	0.071	0.079
L	0.550REF		0.022REF	
L1	0.300	0.500	0.012	0.020
θ	0°	8°	0°	8°