



Product Summary

V _{(BR)DSS}	R _{DS(on)TYP}	I _D
55V	88mΩ@4.5V	3A
	95mΩ@2.5V	
	111mΩ@1.8V	

Feature

- Trench Technology Power MOSFET
- Low R_{DS(ON)}
- Low Gate Charge

Application

- Load Switch
- DC/DC Converter

MARKING:

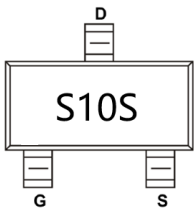

SOT-23

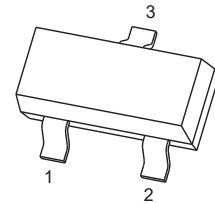

1. GATE
2. SOURCE
3. DRAIN

Schematic diagram

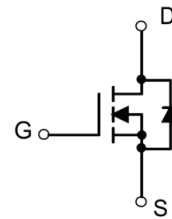

ABSOLUTE MAXIMUM RATINGS (T_A = 25°C unless otherwise noted)

Parameter	Symbol	Value	Unit
Drain - Source Voltage	V _{DS}	55	V
Gate - Source Voltage	V _{GS}	±12	V
Continuous Drain Current ^{1,5}	T _A = 25°C	I _D	3
	T _A = 100°C	I _D	2
Pulsed Drain Current ²	I _{DM}	12	A
Power Dissipation ^{4,5}	P _D	1.2	W
Thermal Resistance from Junction to Ambient ⁵	R _{θJA}	105	°C/W
Junction Temperature	T _J	150	°C
Storage Temperature	T _{STG}	-55~ +150	°C

MOSFET ELECTRICAL CHARACTERISTICS (T_A = 25°C unless otherwise noted)

Parameter	Symbol	Test Condition	Min	Type	Max	Unit
Off Characteristics						
Drain - Source Breakdown Voltage	V _{(BR)DSS}	V _{GS} = 0V, I _D = 250μA	55			V
Zero Gate Voltage Drain Current	I _{DSS}	V _{DS} = 60V, V _{GS} = 0V			1	μA
Gate - Body Leakage Current	I _{GSS}	V _{GS} = ±12V, V _{DS} = 0V			±100	nA
On Characteristics³						
Gate Threshold Voltage	V _{GS(th)}	V _{DS} = V _{GS} , I _D = 250μA	0.4	0.7	1.4	V
Drain-source On-resistance	R _{DS(on)}	V _{GS} = 4.5V, I _D = 3A		88	130	mΩ
		V _{GS} = 2.5V, I _D = 3A		95	140	
		V _{GS} = 1.8V, I _D = 3A		111	167	
Dynamic Characteristics						
Input Capacitance	C _{iss}	V _{DS} = 30V, V _{GS} = 0V, f = 1MHz		662		pF
Output Capacitance	C _{oss}			29		
Reverse Transfer Capacitance	C _{rss}			24		
Gate Resistance	R _g	V _{DS} = 0V, V _{GS} = 0V, f = 1MHz		3.6		Ω
Switching Characteristics						
Total Gate Charge	Q _g	V _{DS} = 30V, V _{GS} = 10V, I _D = 3A		20		nC
Gate-source Charge	Q _{gs}			1.1		
Gate-drain Charge	Q _{gd}			2.8		
Turn-on Delay Time	t _{d(on)}	V _{DD} = 30V, V _{GS} = 10V, I _D = 1.5A, R _G = 1Ω		7		ns
Turn-on Rise Time	t _r			15		
Turn-off Delay Time	t _{d(off)}			15		
Turn-off Fall Time	t _f			10		
Source - Drain Diode Characteristics						
Diode Forward Voltage ³	V _{SD}	V _{GS} = 0V, I _S = 3A			1.2	V

Notes :

- 1.The maximum current rating is limited by package.
- 2.Pulse Test : Pulse Width ≤ 10μs, duty cycle ≤ 1%.
- 3.Pulse Test : Pulse Width ≤ 300μs, duty cycle ≤ 2%.
- 4.The power dissipation P_D is limited by T_{J(MAX)} = 150°C.
- 5.Device mounted on 1in² FR-4 board with 2oz. Copper, in a still air environment with T_A =25°C.

Typical Characteristics

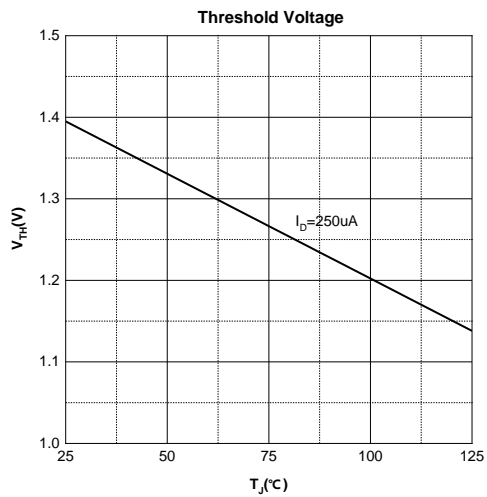
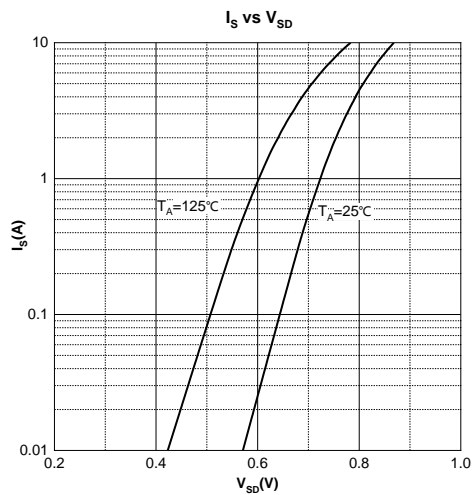
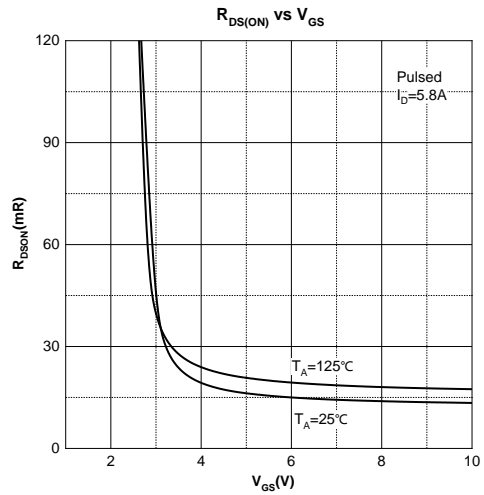
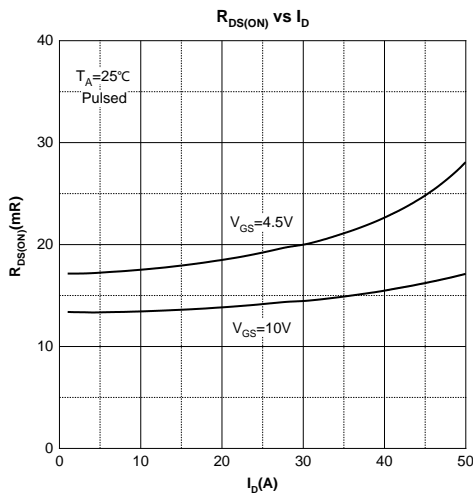
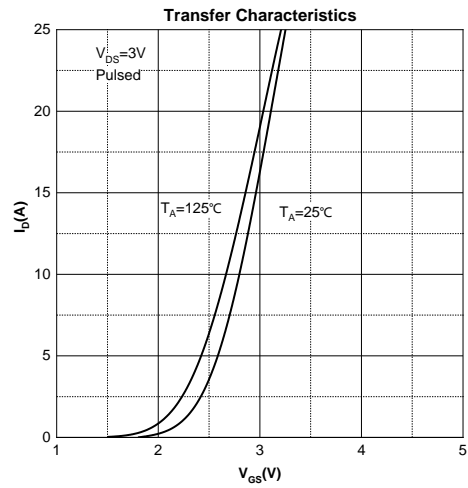
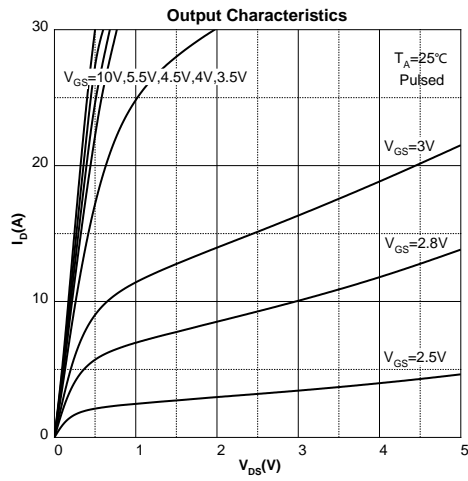

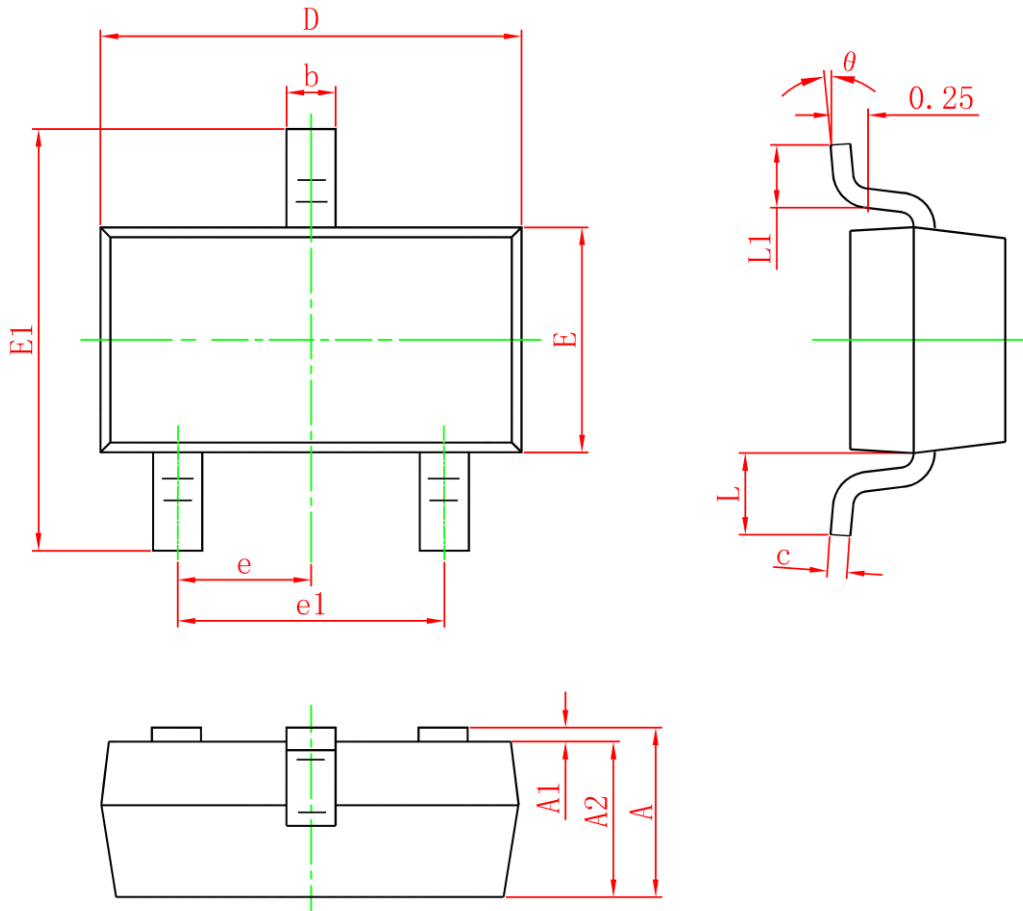
SOT-23 Package Information

Symbol	Dimensions In Millimeters		Dimensions In Inches	
	Min.	Max.	Min.	Max.
A	0.900	1.150	0.035	0.045
A1	0	0.100	0	0.004
A2	0.900	1.050	0.035	0.041
b	0.300	0.500	0.012	0.020
c	0.080	0.150	0.003	0.006
D	2.800	3.000	0.110	0.118
E	1.150	1.500	0.045	0.059
E1	2.250	2.650	0.089	0.104
e	0.950TYP		0.037TYP	
e1	1.800	2.000	0.071	0.079
L	0.550REF		0.022REF	
L1	0.300	0.500	0.012	0.020
θ	0°	8°	0°	8°